

Borough Council of  
**King's Lynn &  
West Norfolk**



# **Cabinet**

## **Agenda**

**Tuesday, 1st December, 2015**  
at 5.30 pm

in the

**Committee Suite  
King's Court  
Chapel Street  
King's Lynn**



If you require parts of this document in another language, large print, audio, Braille or any alternative format please contact the Council Information Centre on 01553 616200 and we will do our best to help.

#### **LATVIAN**

Ja Jums nepieciešamas daļas no šī dokumenta citā valodā, lielā drukā, audio, Braila rakstā vai alternatīvā formātā, lūdzu, sazinieties ar Padomes informācijas centru (Council Information Centre) pa 01553 616200 un mēs centīsimies Jums palīdzēt.

#### **RUSSIAN**

Если вам нужны части этого документа на другом языке, крупным шрифтом, шрифтом Брайля, в аудио- или ином формате, обращайтесь в Информационный Центр Совета по тел.: 01553 616200, и мы постараемся вам помочь.

#### **LITHUANIAN**

Jei pageidaujate tam tikros šio dokumento dalies kita kalba, dideliu šriftu, Brailio raštu, kitu formatu ar norite užsisakyti garso įrašą, susisiekite su Savivaldybės informacijos centru (Council Information Centre) telefonu 01553 616200 ir mes pasistengsime jums kiek įmanoma padėti.

#### **POLISH**

Jeśli pragną Państwo otrzymać fragmenty niniejszego dokumentu w innym języku, w dużym druku, w formie nagrania audio, alfabetem Braille'a lub w jakimkolwiek innym alternatywnym formacie, prosimy o kontakt z Centrum Informacji Rady pod numerem 01553 616200, zaś my zrobimy, co możemy, by Państwu pomóc.

#### **PORTUGUESE**

Se necessitar de partes deste documento em outro idioma, impressão grande, áudio, Braille ou qualquer outro formato alternativo, por favor contacte o Centro de Informações do Município pelo 01553 616200, e faremos o nosso melhor para ajudar.



King's Court, Chapel Street, King's Lynn, Norfolk, PE30 1EX  
Telephone: 01553 616200  
Fax: 01553 691663

**CABINET AGENDA**

**DATE:** CABINET - TUESDAY, 1ST DECEMBER, 2015

**VENUE:** COMMITTEE SUITE, KING'S COURT, CHAPEL STREET, KING'S LYNN

**TIME:** 5.30 pm

**As required by Regulations 5 (4) and (5) of The Local Authorities (Executive Arrangements) (Meetings and Access to Information) (England) Regulations 2012 - No Items will be considered in private.**

**1. MINUTES**

To approve the Minutes of the Meeting held on 3 November 2015 (previously circulated pages 431- 441).

**2. APOLOGIES**

To receive apologies for absence.

**3. URGENT BUSINESS**

To consider any business, which by reason of special circumstances, the Chairman proposes to accept, under Section 100(b)(4)(b) of the Local Government Act 1972.

**4. DECLARATIONS OF INTEREST**

Please indicate if there are any interests which should be declared. A declaration of an interest should indicate the nature of the interest (if not already declared on the Register of Interests) and the agenda item to which it relates. If a disclosable pecuniary interest is declared, the member should withdraw from the room whilst the matter is discussed.

These declarations apply to all Members present, whether the Member is part of the meeting, attending to speak as a local Member on an item or simply observing the meeting from the public seating area.

**5. CHAIRMAN'S CORRESPONDENCE**

To receive any Chairman's correspondence.

**6. MEMBERS PRESENT UNDER STANDING ORDER 34**

To note the names of any Councillors who wish to address the meeting under Standing Order 34.

**7. CALLED IN MATTERS**

To report on any Cabinet Decisions called in.

**8. FORWARD DECISIONS (Pages 6 - 7)**

A copy of the Forward Decisions List is attached

**9. MATTERS REFERRED TO CABINET FROM OTHER BODIES**

To receive any comments and recommendations from other Council bodies which meet after the dispatch of this agenda. Copies of any additional comments made will be circulated as soon as they are available.

- Resources and Performance Panel – 24 November 2015
- Audit Committee – 24 November 2015
- Regeneration and Development Panel – 25 November 2015
- Environment and Community Panel – 25 November 2015

**10. HACKNEY CARRIAGE AND PRIVATE HIRE LICENSING PROCEDURES AND CONDITIONS (Pages 8 - 96)**

**11. STRATEGIC FORUM: FREEBRIDGE COMMUNITY HOUSING & BOROUGH COUNCIL OF KING'S LYNN & WEST NORFOLK (Pages 97 - 101)**

To: Members of the Cabinet

Councillors A Beales (Vice-Chairman), R Blunt, N Daubney (Chairman), Lord Howard, A Lawrence, B Long, Mrs E Nockolds and D Pope

Cabinet Scrutiny Committee

For Further information, please contact:

Sam Winter, Democratic Services Manager 01553 616327

Borough Council of King's Lynn & West Norfolk  
King's Court, Chapel Street  
King's Lynn PE30 1EX

**FORWARD DECISIONS LIST**

<b>Date of meeting</b>	<b>Report title</b>	<b>Description of report</b>	<b>Key or Non Key Decision</b>	<b>Decision Maker</b>	<b>Cabinet Member and Lead Officer</b>	<b>List of Background Papers</b>	<b>Public or Private Meeting</b>
1 December 2015	Hackney Carriage & Private Hire Licensing Conditions & Procedures Review		Non	Council	Community Exec Director – G Hall		Public
	Freebridge/Council Liaison Board		Non	Cabinet	Housing and Community Chief Executive		Public

<b>Date of meeting</b>	<b>Report title</b>	<b>Description of report</b>	<b>Key or Non Key Decision</b>	<b>Decision Maker</b>	<b>Cabinet Member and Lead Officer</b>	<b>List of Background Papers</b>	<b>Public or Private Meeting</b>
12 January 2016	Final Council Tax Support Scheme 2016/17		Key	Council	Leader Asst Exec Dir – L Gore		Public
	Council Tax Support Discretionary Hardship Fund 1016/17		Key	Council	Leader Asst Exec Dir – L Gore		Public
	Switched on - Transformation Strategy		Non	Council	Exec Dir – D Gates Leader		Public
	Community Infrastructure Levy		Key	Council	Housing and Community Exec Director – G Hall		Public
	The Statement of Community Involvement		Non	Cabinet	Development Exec Director G Hall		Public
	Smoke and Carbon Monoxide Alarm Regulations 2015		Non	Cabinet	Housing and Community Chief Executive		Public
	Corporate Business Plan 2015-19		Key	Council	Chief Executive		Public
	Electoral Review		Key	Council	Leader Chief Executive		Public
	Affordable Housing Company		Non	Cabinet	Housing & Community Chief Executive		Public
	Proposed Surgery Development – King's Lynn		Key	Council	Regeneration& Industrial Assets Exec Dir – C Bamfield		Private- Private - Contains exempt Information under para 3 –

Agenda Item 8

							information relating to the business affairs of any person (including the authority)
	Charging Policy for Electric Vehicles		Non	Cabinet	ICT Leisure & Public Space and Environment Exec Dir – C Bamfield		Public
	Destination Management Plan		Non	Cabinet	Culture Heritage and Health Chief Executive		Public

<b>Date of meeting</b>	<b>Report title</b>	<b>Description of report</b>	<b>Key or Non Key Decision</b>	<b>Decision Maker</b>	<b>Cabinet Member and Lead Officer</b>	<b>List of Background Papers</b>	<b>Public or Private Meeting</b>
2 February 2016	Budget 2016/17		Key	Council	Leader Asst Exec Dir – L Gore		Public

**REPORT TO CABINET**

<b>Open</b>		Would any decisions proposed :		
<b>Any especially affected Wards</b>	Operational	(a) Be entirely within cabinet's powers to decide YES/NO (b) Need to be recommendations to Council YES/NO (c) Be partly for recommendations to Council and partly within Cabinets powers – YES/NO		
Lead Member: Cllr Adrian Lawrence E-mail: <a href="mailto:cldr.adrian.lawrence@west-norfolk.gov.uk">cldr.adrian.lawrence@west-norfolk.gov.uk</a>		Other Cabinet Members consulted:		
		Other Members consulted: Cllr Donald Tyler		
Lead Officer: Vicki Hopps E-mail: <a href="mailto:vicki.hopps@west-norfolk.gov.uk">vicki.hopps@west-norfolk.gov.uk</a> Direct Dial: 01553 616307		Other Officers consulted: Marie Malt; John Gilbraith		
Financial Implications YES/NO	Policy/Personnel Implications YES/NO	Statutory Implications YES/NO	Equal Opportunities Implications YES/NO	Risk Management Implications YES/NO

Date of meeting: 1<sup>st</sup> December 2015

**HACKNEY CARRIAGE AND PRIVATE HIRE LICENSING PROCEDURES AND CONDITIONS**

**Summary**

The procedures and conditions have been updated following various changes in legislation since the last conditions were approved by Full Council on 30<sup>th</sup> June 2011. A number of procedures and conditions have also been reviewed with the aim of streamlining procedures and providing more protection for the public.

**Recommendation**

The Council adopt the revised procedures and conditions.

**Reason for Decision**

To keep the current procedures and conditions up to date and fit for purpose.

**1.0 Introduction**

1.1 The Borough Council of King's Lynn & West Norfolk has adopted the provisions of the Local Government (Miscellaneous Provisions) Act 1976 that relate to the licensing of hackney carriages and private hire vehicles, hackney carriage and private hire drivers and private hire operators. The Act permits Local Authorities to attach conditions to the licenses issued to vehicles, drivers and operators. The purpose of this licensing regime is to ensure the safety of the travelling public, other road users, pedestrians, and the drivers of licensed vehicles. Commercial concerns of the trade can be taken into account but are secondary to the safety aspects of licensing. The last full review of licensing conditions was approved by Full Council on 30<sup>th</sup> June 2011.



## **2.0 Consultation**

2.1 The trade were consulted on the proposed procedures and conditions between 17<sup>th</sup> August 2015 and 30<sup>th</sup> September 2015. A copy of the consultation document can be found in the background papers.

2.2 The response to the consultation was disappointing with only 26 responses (9%) received from the trade. A copy of all the responses received from the trade can be found in the background papers.

## **3.0 Proposals**

3.1 Legislative Changes. Changes in various different types of legislation have required the Borough Council to update the procedures and conditions accordingly. These changes are summarised below:

3.1.1 In December 2012 the functions of the Criminal Records Bureau (CRB) and the Independent Safeguarding Authority (ISA) were merged and are now carried out by the Disclosure Barring Service (DBS). Reference to the CRB has been changed to DBS throughout the conditions and procedures document.

3.1.2 Since October 2014, the paper tax disc was not required to be displayed in a vehicle. As a result, the conditions and procedures have been changed to reflect the new position to display the internal vehicle licence.

3.1.3 Since June 2015, the paper counterpart of the DVLA driving licence was no longer valid. Paper licences issued before 1998 when the photo card was introduced are still valid. The requirement to produce the paper part of the DVLA driving licence is not required if a photo card is held.

3.1.4 From 1<sup>st</sup> October 2015, the Deregulation Act 2015 requires all hackney carriage and private hire driver's licenses to be issued for a period of 3 years, and private hire operator licences for 5 years, unless a shorter period is appropriate. The licensing conditions and procedures have been updated to reflect this statutory change.

3.2 Guidelines Relating to the Relevance of Convictions. The current policy is based on a DFT circular which was circulated in 1992 and is not fit for purpose, particularly in light of the recent child exploitation matters involving taxi drivers. It is proposed to introduce new guidelines relating to the relevance of convictions to ensure that stricter guidelines are applied when considering the suitability of licensed drivers. This will also make potential applicants and existing licence holders aware of the guidelines.

3.3 Change in Age/Mileage Policy. It is proposed to change the mileage policy for licensed hackney carriage and private hire vehicles from up to 5 years and up to 60,000 miles upon new application to up to 5 years and up to 70,000 miles. Under the proposal vehicle applications would be processed as follows:

		Age, months/years							
		0-11m 0-1y	12-23m 1-2y	24-35m 2-3y	36-47m 3-4y	48-59m 4-5y	60-71m 5-6y	72-80m 6-7y	81+m 7+
Mileage	5,000	Green	Green	Green	Green	Green	Yellow	Yellow	Red
	10,000	Green	Green	Green	Green	Green	Yellow	Yellow	Red
	15,000	Green	Green	Green	Green	Green	Yellow	Yellow	Red
	20,000	Green	Green	Green	Green	Green	Yellow	Yellow	Red
	25,000	Green	Green	Green	Green	Green	Yellow	Yellow	Red
	30,000	Green	Green	Green	Green	Green	Yellow	Yellow	Red
	35,000	Green	Green	Green	Green	Green	Yellow	Yellow	Red
	40,000	Green	Green	Green	Green	Green	Yellow	Yellow	Red
	45,000	Green	Green	Green	Green	Green	Yellow	Yellow	Red
	50,000	Green	Green	Green	Green	Green	Yellow	Yellow	Red
	55,000	Green	Green	Green	Green	Green	Yellow	Red	Red
	60,000	Green	Green	Green	Green	Green	Yellow	Red	Red
	65,000	Green	Green	Green	Green	Green	Red	Red	Red
	70,000	Green	Green	Green	Green	Green	Red	Red	Red
	75,000	Yellow	Yellow	Yellow	Yellow	Red	Red	Red	Red
	80,000	Yellow	Yellow	Yellow	Yellow	Red	Red	Red	Red
85,000	Red	Red	Red	Red	Red	Red	Red	Red	
90,000	Red	Red	Red	Red	Red	Red	Red	Red	

	Fully meets policy – granted using delegated authority
	May be granted by authorised officers in exceptional circumstances
	Vehicles in this category will be refused using delegated authority

3.4 It is proposed to retain the upper age limit to 10 years with unlimited mileage for vehicle renewals. It is, however proposed that renewal applications not meeting this 10 year policy are dealt with as follows:

		Age (years)			
		Up to 10	11-12	13-14	15+
Mileage	150,000, or less	Green	Yellow	Yellow	Yellow
	160,000	Green	Yellow	Yellow	Yellow
	170,000	Green	Yellow	Yellow	Red
	180,000	Green	Yellow	Yellow	Red
	190,000	Green	Yellow	Yellow	Red
	200,000	Green	Yellow	Yellow	Red
	210,000	Green	Yellow	Red	Red
	220,000	Green	Yellow	Red	Red
	230,000	Green	Yellow	Red	Red
	240,000	Green	Yellow	Red	Red
	250,000 +	Green	Red	Red	Red

Green	Fully meets policy – granted using delegated authority
Yellow	May be granted by authorised officers in exceptional circumstances
Red	Vehicles in this category will be refused using delegated authority

3.5 Right to Work Check. Guidance issued by the Department of Transport states that licensing authorities should carry out right to work checks on individuals applying for hackney carriage and private hire licenses. The East of England Immigration Officer has also requested the Borough Council carry out such checks. It is therefore proposed to introduce the requirement for all applicants to provide prescribed documentation upon application.

3.6 Other Proposed Amendments. It is proposed to make a number of minor amendments to the conditions. A summary of these proposals are attached to this report as Appendix 1.

3.7 A revised copy of the Hackney Carriage and Private Hire Licensing Procedures and Conditions which has been updated to reflect the proposed changes can be found in Appendix 2.

#### 4.0 Financial Implications

There are no additional staffing requirements or other associated costs.

## **5.0 Statutory Implications**

In order not to exacerbate crime and disorder, particularly late at night, it is essential that there is a fleet of safe, properly licensed taxi and private hire vehicles to take people home. The proposals should help to ensure that the trade fully understands its obligations and that enforcement will be transparent.

## **6.0 Background Papers**

1. Hackney Carriage and Private Hire Licensing Procedures and Conditions, June 2011.
2. Consultation Document – Hackney Carriage and Private Hire Review of Conditions dated 17<sup>th</sup> August 2015.
3. Responses received from the licensed hackney carriage and private hire trade from the consultation.

## **7.0 Appendices**

Appendix 1 - Proposals Summary

Appendix 2 - Revised Hackney Carriage and Private Hire Licensing Procedures and Conditions Booklet.

## Hackney Carriage & Private Hire Licensing Conditions & Procedures Review

### Legislation Changes

Summary of change	Reason for proposed change
Combined Hackney Carriage/Private Hire Driver Licenses will be issued for the duration of 3 years.	Change in Law - Deregulation Act 2015. Applicable from 1 <sup>st</sup> October 2015
Private Hire Operator Licenses will be issued for the duration of 5 years.	Change in Law - Deregulation Act 2015. Applicable from 1 <sup>st</sup> October 2015
Licensed Private Hire Operators will have the ability to sub-contract work to licensed private hire operators out of the area governed by The Borough Council of King's Lynn & West Norfolk.	Change in Law - Deregulation Act 2015. Applicable from 1 <sup>st</sup> October 2015
The Criminal Records Bureau has changed to The Disclosure & Barring Service (CRB – DBS)	In December 2012 the functions of the CRB and the ISA (Independent Safeguarding Authority) were merged and are now carried out by the DBS.
The paper part of a DVLA Driving Licence is not required if a photo card is held.	Since June 2015, the paper counterpart to the photo card licence is not valid. Paper licences issued before 1998 when the photo card was introduced are still valid.
Removal of tax disc – change in location description for internal licence plate in all vehicles.	Since October 2014, the paper tax disc was no longer required to be displayed on a vehicle.

### Other proposed changes

Ref	Summary of change	Reason for proposed change
2.23	Death of Licence holder – 3 months to transfer vehicle licence.	Previously 28 days, trade rep 3m.
2.8	Right to Work Check – Immigration officer contact.	Guidance issued by the Department of Transport states licensing authorities should carry out such a check. East of England Immigration have requested this check be carried out.
3.11	Change in Age/Mileage Policy to allow vehicles up to 5 years, 70k. Up to 4 years 80K. Up to 6 years 60K. Up to 7 years 50K.	Representation from Trade.
3.22 & 3.38	Altered vehicles (not M1 spec) require Driver and Vehicle Standards Agency (DVSA) Individual Vehicle approval (IVA) or Voluntary	Advice from DVSA

	Individual Vehicle Approval (VIVA) inspection must be undertaken and a satisfactory report produced. Cat A and B write offs will not be licensed.	
3.30	No bull bars	Safety concerns
3.49	CCTV outward (no audio) for insurance purposes	Issues raised internally regarding data control.
3.72	Introduction of capability to have trailers (for luggage) and trailer plate.	Requests from trade to tow trailers on licensed vehicles.
5.3	Private hire vehicle signage – Dual system including either operator name or not Pre-Booked Only – ‘Insurance invalid unless booked with operator’.	Requests from trade to have generic signage on Private Hire Vehicles & to raise awareness to public.
5.4	Reinstatement of vehicle licences – previously within 12 months, now 3m.	Condition originally created to allow vehicles under repair to be re-licensed if their licence expired during the repair period. 12m too long.
6.4	Addition of novelty vehicles category	New vehicle category to cover different novelty private hire vehicles, i.e. fire engine.
7.34	Passenger Transport badge holders to inform BCKLWN if suspended or revoked.	In the interests of Public Safety.
7.35	The use of Electronic Cigarettes (e-cigs), Personal Vaporizers (PV) and Electronic Nicotine Delivery Systems (ENDS) only permitted when not carrying fare paying passengers.	It is not clear until further research is undertaken whether such devices can cause harm or not.
7.36	Suspension of driver/vehicle licenses for failure to provide required information, i.e. Medical/DBS/DVLA etc.	Requirement to ensure necessary information is provided in the interests of public safety, during the course of a licence, particularly as moving to 3 and 5 year licenses.
8.28	Operators must ensure that non-licensed staff, i.e. controllers, cleaners etc behave in a civilised and appropriate manner when involved in the operation of the business. This includes discussion on social media sites.	To prevent inappropriate behaviour.
10.4 (PP33	Addition of penalty points for Road Traffic Act offences, defective lights etc and failure to	Light touch approach to minor traffic

- PP35)	comply with HC/PH legislation	offences and breaches of legislation.
Annex A	New accident/damage notification form	Includes requirement to draw a diagram of the scene of the accident.
Annex B	New 'guidelines relating to the relevance of convictions' policy.	The current policy is based on a DFT circular which was circulated in 1992 and is not fit for purpose.

Borough Council of  
**King's Lynn &  
West Norfolk**



# **Hackney Carriage And Private Hire Licensing Procedures & Conditions**



## Table of Contents

<b>Definitions</b>	<b>Page 2</b>
<b>Mission Statement</b>	<b>Page 3</b>
	<b>Paragraph</b>
<b>Introduction</b>	<b>1.0</b>
▪ The Borough Council's Role in Taxi Licensing	1.2
▪ Licensing & Appeals Panel	1.17
▪ The Hearing	1.21
▪ Right of Appeal	1.27
<b>Application Process</b>	<b>2.0</b>
▪ Disclosure and Barring Service (DBS) & Right to Work Checks	2.2
▪ Driver's Medical	2.10
▪ DVLA Mandate	2.11
▪ Knowledge Test	2.13
▪ Operators Application	2.14
▪ Vehicle Application	2.15
▪ Renewals Applications	2.19
▪ Refund of Licence Fees	2.21
<b>All Vehicles</b>	<b>3.0</b>
• Duration of Licence	3.2
• Vehicle Replacement	3.3
• Insurance	3.6
• Excise Licence & Registration documents	3.9
• Age Requirements	3.11
• Vehicle Licence Renewals	3.14
• Vehicle Specifications	3.18
• Carriage of Portable Oxygen Tanks	3.31
• Vehicle Testing Standards	3.32
• Accidents	3.41
• First Aid & Fire Equipment	3.42
• Radio Scanning Devices	3.48
• CCTV	3.49
• LPG	3.55
• Tinted Windows	3.59
• Advertising	3.64
• Licence Plates	3.66
• Complaints	3.72
<b>Hackney Carriage Vehicles</b>	<b>4.0</b>
• Wheelchair Accessible Specifications	4.2
• Insurance	4.10
• Transfer of Interest	4.13
• Taximeters	4.14
• Roof Signs	4.24
• Vehicle Inspections	4.28
• Unattended Taxis	4.35

<b>Private Hire Vehicles</b>	<b>5.0</b>
<ul style="list-style-type: none"> <li>• Roof Signs</li> <li>• Signage</li> <li>• Change of Use</li> <li>• Transfer</li> </ul>	5.1 5.2 5.4 5.5
<b>Special Event Vehicles</b>	<b>6.0</b>
<ul style="list-style-type: none"> <li>• Sale of Alcohol</li> <li>• Types of Vehicle</li> <li>• Age Requirements</li> <li>• Licence Plate</li> <li>• Dress Code</li> <li>• Stretched Limousines</li> <li>• Replacement parts</li> <li>• Window tints</li> <li>• Special Event Operators – Additional Requirements</li> </ul>	6.2 6.3 6.4 6.7 6.9 6.11 6.15 6.16 6.17
<b>Drivers</b>	<b>7.0</b>
<ul style="list-style-type: none"> <li>• General requirements</li> <li>• Conduct of Driver</li> <li>• Change of Address</li> <li>• Change of Operator</li> <li>• Convictions, Cautions, Driving Offences &amp; Charges</li> <li>• Badges</li> <li>• Lost Property</li> <li>• Animals</li> <li>• Fare to be demanded/Receipts</li> </ul>	7.1 7.11 7.12 7.13 7.14 7.18 7.27 7.29 7.32
<b>Private Hire Operators</b>	<b>8.0</b>
<ul style="list-style-type: none"> <li>• General requirements</li> <li>• Complaints</li> <li>• Change of Address</li> <li>• Convictions</li> </ul>	8.1 8.21 8.22 8.23
<b>Hackney Carriage Driver Byelaws</b>	<b>9.0</b>
<b>Penalty Points Systems</b>	<b>10.0</b>
<b>Town Police Clauses Act 1847 (Summary of Offences)</b>	<b>11.0</b>
<b>LG (MP) Act 1976 (Hackney Carriage Provisions)</b>	<b>12.0</b>
<b>LG (MP) Act 1976 (Private Hire Provisions)</b>	<b>13.0</b>
<b>Vehicle Accident Notification Form</b>	<b>Annex A</b>
<b>Guidelines relating to the relevance of convictions</b>	<b>Annex B</b>
<b>Immediate revocation of HC/PH Driver's Licence</b>	<b>Annex C</b>
<b>HC &amp; PH Vehicle Compliance Testing Standards (Code of Practice)</b>	<b>Annex D</b>

## Definitions

- “**Borough Council**” means the Borough Council of King's Lynn & West Norfolk.
- “**Authorised officer**” means an officer of the Borough Council authorised in writing;
- “**Driver's licence**” means, in relation to the driver of a hackney carriage, a licence under section 46 of the Town Police Clauses Act 1847 and, in relation to the driver of a private hire vehicle, a licence under section 51 of Local Government (Miscellaneous Provisions) Act 1976;
- “**Hackney carriage**” means a carriage exposed for hire to the public, whether standing in the public street or a private yard. The name is derived from an old French word denoting an ambling horse or mare: Oxford English Dictionary;
- “**Hackney carriage byelaws**” means the byelaws for the time being in force in the controlled district of the Borough Council relating to hackney carriages;
- “**Private Hire Vehicle**” is a motor vehicle constructed or adapted to seat fewer than nine passengers, other than a hackney carriage or public service vehicle which is provided for hire with the services of a driver for the purpose of carrying passengers. Private hire vehicles cannot ply for hire on a rank or be hailed in the street and must be pre-booked through a private hire operator licensed by the Borough Council.
- “**Operate**” means in the course of business to make provision for the invitation or acceptance of bookings for a private hire vehicle;
- “**Operator's licence**” means a licence issued by the Borough Council under section 55 of the Local Government (Miscellaneous Provisions) Act 1976;
- “**Taximeter**” means any device for calculating the fare to be charged in respect of any journey in a hackney carriage by reference to the distance travelled or time elapsed since the start of the journey, or a combination of both;
- “**Vehicle licence**” means in relation to a hackney carriage a licence under sections 37 to 45 of the Town Police Clauses Act 1847 and in relation to a private hire vehicle means a licence under section 48 of Local Government (Miscellaneous Provisions) Act 1976. Once a vehicle is licensed it remains so 24/7 and must be driven at all times by a person who holds a combined driver's licence issued by the Borough Council.
- “**Special Event Vehicle**” means a private hire vehicle exclusively used for special occasions. For further information see Section 6.
- “**Hackney Rank/Stand**” A designated place adopted by the Borough Council where hackney carriages can wait the arrival of a hirer.
- “**Notify the Borough Council**” means notify the Licensing Team at the Borough Council in writing.

## The Purpose of Licensing / Licensing Objectives

The objective of the licensing regime is to ensure that, so far as possible, those licensed to drive Hackney Carriages and Private Hire vehicles are suitable persons to do so, namely that they are safe drivers with good driving records and adequate experience, sober, mentally and physically fit, and honest; and that they are persons who would not take advantage of their position to abuse, assault or defraud customers. The general term used is a 'fit and proper' person.

This Authority expects all licensed vehicles to be maintained to the highest standard, and all vehicles to be kept to an 'exceptional' standard.

We also expect the Operators to provide first class customer service and advice to their customers, in order to promote the high quality we ourselves aim to bring to those who live in, work in, or visit the area.

### 1.0 Introduction

- 1.1 The Borough Council of King's Lynn & West Norfolk is situated in the County of Norfolk. The Council area has a population of approximately 149,000 making it the largest in the County in terms of population. In terms of area it is also the largest, covering 1428.76 square kilometres (550 square miles). The Borough area is mainly rural with urban areas of King's Lynn, Downham Market and Hunstanton. These areas are shown on the following map:

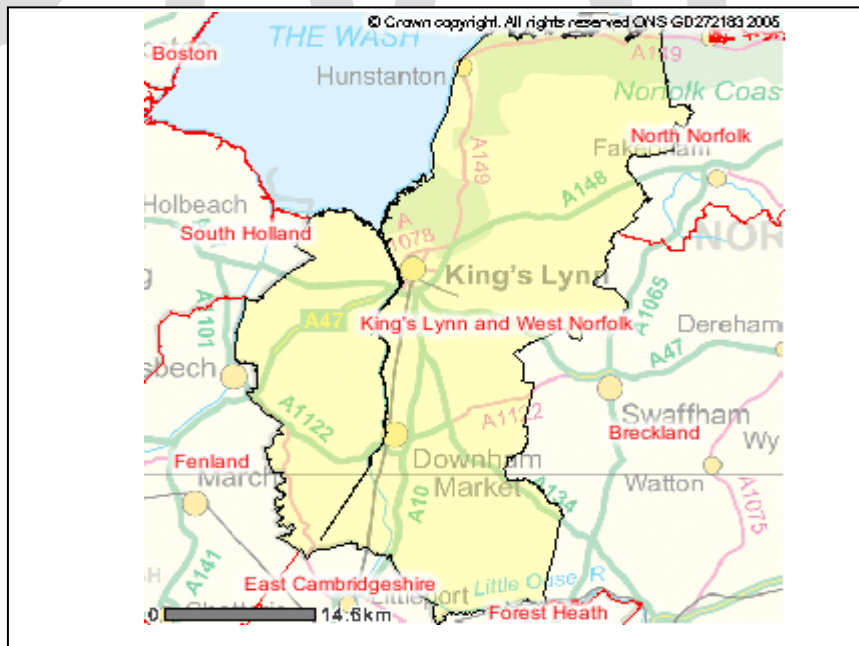

## The Borough Council's Role in Taxi Licensing

- 1.2 The Borough Council is responsible for the licensing of all hire vehicles which operate within the district, which are provided with a driver and operated with less than nine passenger seats.
- 1.3 There are two types of vehicle: public hire vehicles (**hackney carriages**) and vehicles which are only available by prior booking arrangement (**private hire vehicles**). Although the description 'taxi' should only be applied to a hackney carriage any hire vehicle is usually known as a 'taxi' by the public.
- 1.4 Before any vehicle is licensed it must be tested at one of the Borough Council's approved garages. The test covers the vehicle's mechanics and general appearance, which includes the comfort for passengers and the reliability of any meter fitted.
- 1.5 Private Hire vehicles may only undertake journeys in response to advance bookings. The Borough Council is also responsible for granting private hire operators licences for the premises at which these bookings are made.
- 1.6 The Borough Council is responsible for the licensing of the drivers of both classes of vehicle. Within the scope of legislation the Borough Council ensures that all drivers are 'fit and proper persons' to be licensed by carrying out checks on an applicant's background.
- 1.7 The Borough Council issue dual driver's licences to all successful applicants, which enables the holder to drive either a hackney carriage vehicle or a private hire vehicle provided that these vehicles are licensed by this authority.
- 1.8 As part of ensuring drivers are suitable for the job, the Borough Council carries out enhanced **Disclosure and Barring Service checks**. For more information, visit the **Disclosure and Barring Service (DBS) website at [www.gov.uk/government/.../disclosure-and-barring-service](http://www.gov.uk/government/.../disclosure-and-barring-service)**.
- 1.9 The Borough Council also has a responsibility as the 'Enforcement Agency' of the drivers, vehicles and operators it has licensed. Enforcement covers offences related to 'taxi' legislation, driver's behaviour, the condition of the vehicles and the investigation of complaints made against any licence holder.
- 1.10 As well as granting and issuing licences the Borough Council also has the power to suspend or revoke licences and take Court action if necessary against any offending licence holder.
- 1.11 Licensing and enforcement is carried out by Borough Council officers appointed 'Authorised Officers' for that purpose and they have been issued with written authority to do so as well as having a Borough Council identity badge.

## **Wheelchair accessible hire vehicles**

- 1.12 There are a growing number of wheelchair accessible vehicles available in West Norfolk which are licensed by the Borough Council. All new Hackney Carriage Vehicles (plates 53 onwards) registered with the Borough Council must be wheelchair accessible.
- 1.13 The Borough Council welcomes views and information from the public regarding their needs for wheelchair accessible vehicles, the availability of currently licensed vehicles or what would help to provide an efficient 'taxi' service for people with physical disabilities.

## **Hackney Carriage/Private Hire Drivers Licences**

- 1.14 In considering new applications for Hackney Carriage/Private Hire Drivers Licences and also any breaches during the currency of a licence, the Borough Council must be satisfied that drivers are fit and proper persons to hold a Licence.
- 1.15 In doing so, they must have regard to all convictions, police cautions, charges, driving convictions, complaints of unacceptable conduct /behaviour, breach of licence conditions and other convictions obtained during the course of a Licence, in accordance with the convictions policy (Annex B).
- 1.16 When such circumstances occur the application may be referred to a Panel of the Licensing & Appeals Board for determination.

## **Referral to Panel of Licensing & Appeals Board**

- 1.17 Where an applicant or a driver is referred to the Panel for consideration, they will be notified in writing of the reason and the date, time and venue of the Panel hearing.
- 1.18 They will be advised that they may bring a representative to the hearing. The representative may be a friend, legal representative or a representative from the trade whom they wish to assist them in addressing the Panel in support of their application/disciplinary hearing. But please note that any consultation with a representative should take place in advance of the hearing date and not just prior to the meeting. This will ensure that their case is well prepared for Panel consideration.

## **The Licensing & Appeals Panel**

- 1.19 The Panel will consist of members made up of Borough Councillors. A Chairman is appointed to supervise the Committee during the process. The Committee may be advised by a legal representative.
- 1.20 A number of Borough Council Officers may also attend the hearing, in an advisory capacity. However, they do not take part in the decision making process.

## **The Hearing**

- 1.21 A number of applications and disciplinary matters could be considered on the day, including any historic matters. Each matter will be considered on its own merits and the public will be excluded to protect confidentiality where appropriate. In these circumstances the public will not have access to the meeting unless the applicant requests that they should.
- 1.22 When a person is called to appear before the Panel they and their representative and any complainants will be guided to their seats. They will be asked if they have received a copy of the report regarding the circumstances surrounding their case. The Panel will already have a copy of the report. Where the case arises from a complaint, the complainant, if present, will be asked to explain their complaint to the Panel. They will then be given the opportunity to question the complainant.
- 1.23 They will be asked to describe the circumstances surrounding the convictions or incident concerned and asked to demonstrate to the Panel why they think they are a fit and proper person to hold a Hackney Carriage/ Private Hire Drivers Licence or why they feel disciplinary action should not be taken.

## **The Decision**

- 1.24 When considering convictions, the Panel will have regard to the 'Guidance relating to the relevance of convictions and cautions' a copy of which is attached at Annex B.
- 1.25 After hearing the evidence and representations from all parties, the Panel will retire to make their decision.
- 1.26 As soon as the Panel have come to a decision they will return to the room and inform the persons of their decision. The person will also be advised of the decision in writing together with their rights of appeal. The Panel have a number of options which include the following:
- Grant or refuse application
  - Take no action
  - Issue a verbal warning
  - Suspend or revoke Licence
  - Apply conditions to the licence
  - Require driver to complete DSA and/or sit Borough Council's Knowledge test, or any other action deemed appropriate.

## **Right of Appeal**

- 1.27 If the Borough Council refuses the grant of a Vehicle, Operator or Drivers Licence, or in the case of a disciplinary hearing, decide to suspend or revoke a Drivers Licence or any other formal action, the person will have

the right of appeal to a Magistrates' Court. In the case of refusal to grant a Hackney Carriage Proprietors Licence, appeal will be to the Crown Court.

### **General Advice**

- 1.28 The Licensing & Appeal Panel is a formal meeting where members sit in a quasi-judicial manner. This means that the Panel has to act in a similar fashion to a Court or Tribunal. It is therefore important that persons appearing before Committee should behave and dress in an appropriate manner.
- 1.29 If a person appears before the Panel following a complaint about their conduct, they should not attempt to speak to the complainants / witnesses prior to the meeting as this could be deemed to be harassment.

### **Serving of Notices**

- 1.30 Sub-sections (2) to (5) of S23 of the Local Government Act 1972 shall have effect and are incorporated in the conditions for vehicles, operators and drivers in relation to any notices required or authorised by the conditions to be given or served on the licensee by or on behalf of the Borough Council or any authorised officer.



## 2.0 Application Process

### Driver Application

- 2.1 In addition to the application form, all applications for driver licences must be accompanied by the following:
1. Disclosure and Barring Service form (DBS);
  2. Driver's Medical;
  3. DVLA Driving Licence – (photocard or paper licence)
  4. DVLA Mandate
  5. Fees;
  6. Passport Size Photograph certified as being a true likeness;
  7. Driver Standard Agency (DSA) Hackney Carriage/Private Hire Test Assessment Pass Certificate.

### Disclosure and Barring Service form (DBS) & Right to Work Check

2.2 As part of the application process, the Applicant will obtain (with the applicants consent) a Disclosure and Barring Service check to 'enhanced' standard. The Borough Council of King's Lynn & West Norfolk are a 'registered' body with the DBS and as such, applications for disclosures must be made via this Authority on one of our pre-printed forms. These are available from the Borough Council's Licensing team. When you return your completed form to this department you will be asked for a payment to cover the cost of the DBS process (A cheque should be made payable to BCKLWN). The DBS process takes can take up to 8 weeks. Applicants that already have a disclosure and have signed up to the online update service must provide the original disclosure certificate and the unique online reference number so the Council may access their record online.

2.3 Once you have completed the form in **Black Capital Letters** return it to the Borough Council with the relevant identification. The information will be examined by a member of staff and the details entered onto the back page of the form. The Licensing Officer will check, sign and send your DBS form to the Disclosure and Barring Service. You will be required to provide us with a new Disclosure and Barring Service check every 3 years unless your licence expires beforehand, or you have signed up for the online update service. Should you wish to re-apply you would be required to submit a new DBS disclosure.

2.4 The Disclosure and Barring Service will send the Disclosure to the applicant. The original disclosure document must be produced to the Borough Council's Licensing Team. A disclosure with no convictions will be processed; the disclosure number recorded and the date of issue will be entered onto our computer system. A Disclosure with conviction/s may not necessarily mean that you are not a "fit and proper" person to hold a licence. Borough Council officers only have delegated powers to deal with certain convictions. Depending on the type and age of conviction we may offer you a licence, refuse a licence under delegated powers or we may

refer you to the licensing and appeals board to determine whether you are a “fit and proper” person.

2.5 If an applicant has been resident in any other Country than the UK, preceding an application, a certificate of good conduct from an overseas embassy, or each overseas embassy where the applicant has lived, will be required in addition to the Disclosure and Barring Service Disclosure.

2.6 Usage. Information revealed on a DBS Disclosure will only be used for the purpose of determining an application in relation to hackney carriages or private hire licensing.

2.7 Retention. The Borough Council will retain a copy of the Disclosure and Barring Service Disclosure. The information contained on the original Disclosure is required for the Borough Council to complete a check with those subscribed to the DBS online update service.

### **Right to Work Check**

2.8 All applicants must provide documentation to prove that they have the right to work in the United Kingdom. A ‘Right to work Checklist’ providing a list of valid documentation can be found on the Home Office website. An application from a person who cannot provide the necessary documentation will be refused by officers under delegated authority.

### **Rehabilitation of Offenders Act 1988**

2.9 Applicants for taxi and private hire licensing are exempt from the Rehabilitation of Offenders Act 1988. Therefore all convictions, regardless of how long ago may be taken in consideration when determining applications. However, in the determining the relevance of convictions the Panel will take into account the type of offence, the age of the applicant at the time of the offence and the apparent seriousness of the offence.

### **Driver’s Medical**

2.10 A medical will be required upon initial application and must be carried out by a registered Medical Practitioner. The driver’s application pack contains the medical form, which your doctor will be required to complete. Subsequent medicals will be required at age 45, then every five years after the age of 45 and then annually from the age of 65 years. A driver under the age of 65 with a controlled medical condition may also be required to undergo a full medical annually.

### **DVLA Driving Licence & Mandate**

2.11 You will need to supply your DVLA driving licence with your current address. Holders of Photo-card only driving licences are required to supply the photo card and holders of paper licences are required to provide their paper part. There is a DVLA mandate form in each application pack which

must be completed and signed. This will be sent to the DVLA to obtain your driving licence history. This process takes an average of two weeks.

## Fees

- 2.12 Applications with all the relevant supporting documentation will not be accepted without the appropriate fee. Please note that the Borough Council no longer accepts 'cash' and payment must be made by either cheque or credit/debit card. Any licence in respect of which the licence fee has been paid by cheque shall not be effective until the cheque has been cleared.

*Please note: If you have 9 or more current penalty points and/or any previous convictions appear on your DVLA driving licence we may refer your application to a Panel of the Licensing & Appeals Board to ascertain whether you are a 'fit and proper' person to hold a licence.*

## Knowledge Test

- 2.13 You will need to pass the Borough Council's Knowledge Test as part of the application process. The test will include multi-choice questions on Licensing Conditions, the Highway Code, knowledge of the area and literacy and numeracy and it will be conducted by Licensing at the Borough Council.

## Operators Application

- 2.14 Any person who receives bookings or has contracts for the hire and reward for a private hire vehicle is required to hold an operators licence. The application must be accompanied with a list of vehicles and drivers used by the operator. An operator must be a 'fit and proper person' and is therefore subject to a DBS check (see above).

## Vehicle Application

- 2.15 A vehicle application can be processed within 3 days if all the relevant information has been supplied as below and the vehicle meets current conditions (i.e. age/mileage).
- 2.16 **Registration Document or Bill of Sale.** For initial applications only you will need to prove that you are the lawful keeper of the vehicle by providing an original copy of the vehicles V5 (vehicle registration document). A bill of sale for that vehicle may be produced if the V5 is not available but the bill must include the date of first registration and the original V5 document must be produced within a calendar month.
- 2.17 **Insurance Certificate.** To enable us to licence a vehicle we require sight of an original valid insurance policy, and schedule or cover note for that vehicle covering the vehicle for Private Hire and/or Hackney Carriage work. Faxed or email copies of insurance documents are acceptable provided it is sent direct from the insurance company.

- 2.18 **Vehicle Inspection/MOT.** All vehicles licensed by this Authority require inspection at an approved garage (a list of approved garages can be found on the vehicle application form).

## **Renewal Applications**

### **Vehicle Licence**

- 2.19 Vehicle renewal applications will be accepted up to one calendar month before they are due to expire providing the MOT certificate is no more than one calendar month older than the renewal date. Vehicle licences will not be granted an earlier renewal date than their current expiry date. Vehicle Registration documents (V5C) are not required to be produced upon renewal of a vehicle licence, providing there has been no material changes to that vehicle/document during the preceding licence period.

### **Combined Driver Licence & Private Hire Operator**

- 2.20 Combined Driver Licence renewals will be accepted up to one calendar month before they are due to expire.

*Other than insurance documents sent by email or fax direct from the insurance company all documentation must be originals. Photocopies, scanned or fax copy in other circumstances is not acceptable under any circumstances*

### **Refund of Licence Fees – (not applicable to Insurance/lease vehicles)**

- 2.21 In the event that a driver, vehicle or operator licence is not granted then the Borough Council will refund the licence fee. This does not however apply to the fees paid to other organisations, e.g. DBS, Compliance test etc.
- 2.22 Should a vehicle or operator licence be surrendered during the life of the licence then a pro-rata refund will be given for the unexpired portion of the licence. The date will be calculated from the date the licence is returned to the Borough Council. Refunds will not be given for licences that are revoked.

### **Death of Licence Holder**

- 2.23 A licence will immediately lapse in the event of death of the licence holder. In the case of a vehicle licence, a licence may be transferred using the normal procedure within 3 calendar months. A private hire operator licence may not be transferred into another person's name.

### **3.0 All Vehicles**

- 3.1 The Borough Council will not grant or renew a licence unless satisfied that the vehicle is suitable to be a licensed vehicle, is in a suitable mechanical condition, safe and comfortable.

#### **Duration of Licence**

- 3.2 A vehicle licence, once granted, will be issued for a maximum period of one year, except in the case of a vehicle replacement; see Condition 3.4 (below).

#### **Vehicle Replacement**

- 3.3 Where a vehicle is off the road due to accident damage, subject to satisfactory documentary evidence being produced to the authorised officer, the Borough Council may allow a replacement vehicle that meets the Borough Council's criteria for a hackney carriage/private hire vehicle.
- 3.4 The vehicle will be licensed as a replacement for the accident damaged vehicle for a period not exceeding 3 months. A 50% reduction to the normal application fee and a full licence plate fee will be required.
- 3.5 Whilst being repaired, the vehicle licence will be temporarily suspended and the licence plate must be returned to the authority. Once repaired, a new vehicle inspection report may be required and the suspended licence may be re-instated.

#### **Insurance**

- 3.6 A vehicle must have a current certificate of insurance or cover note which clearly covers the use to which the vehicle is to be put.
- 3.7 It shall be the responsibility of the proprietor of a licensed vehicle to produce proof of continuous insurance cover. The insurance proof is to be reviewed by the licensing authority within seven days of the expiry of the preceding certificate or cover note.
- 3.8 If the proprietor fails to produce a certificate of insurance cover on request he shall produce it forthwith or within seven clear days of the request to an authorised officer of the Borough Council. Failure to comply may result in the immediate suspension of the vehicle licence by authorised officers using delegated authority. The suspension will remain in place until a satisfactory certificate of insurance is produced.

#### **Excise Licence (Road Tax) & Vehicle Registration Document (V5)**

- 3.9 There should be a valid excise licence for the vehicle.

3.10 A full vehicle registration document must be produced at the grant of a licence, or as soon as is reasonable - and following any change to the original document.

### **Age Requirement**

3.11 All Hackney Carriage and Private Hire Vehicles will not normally be considered for licensing unless they are under 5 years of age from date of first registration (date as shown on DVLA registration document) and accrued less than 70,000 miles. Vehicles presented for licensing outside these criteria will be dealt with as follows:

3.12 Vehicles that are:

- 3.12.1 over 5 but less than 6 years old with 60,000 miles or less; or
- 3.12.2 over 6 years but less than 7 years old with 50,000 or less; or
- 3.12.3 less than 4 years old with 80,000 miles or less;

May be considered by authorised officers of the Borough Council using delegated authority who may grant the licence if the vehicle is considered 'exceptional'.

3.13 In the following list are factors that will be taken into consideration in determining 'exceptional', but it is not exhaustive:

- Condition of bodywork (e.g. no dents, scratches, stone, chips or rust around wheel arches);
- Original manufacturer's colour and trim combination;
- Clean and immaculate interior, in original condition, free of damage and with only minor wear and tear;
- Full service history showing regular service dates;
- Full documentation (i.e. garage receipts showing schedule of works carried out);

3.14 Renewal of Vehicle Licences. Renewal applications for Hackney Carriages and Private Hire Vehicles will only be granted up to the 10<sup>th</sup> anniversary of first vehicle registration (date as shown on DVLA V5 registration document) regardless of mileage or the date the licence is renewed. Vehicles that are:

- 3.14.1 Over 10 years but less than 12 years with 240,000 miles or less; or
- 3.14.2 Over 12 years but less than 14 years with 200,000 miles or less; or
- 3.14.3 Over 14 years with less than 160,000 miles

May be granted by authorised officers of the Borough Council using delegated authority provided the vehicle is considered 'exceptional' (see Condition 3.13 above). Vehicles will only be considered under this condition no earlier than one calendar month before the 10<sup>th</sup> anniversary.

- 3.15 Any vehicles presented for licensing that do not meet the above criteria will be refused by authorised officers using delegated powers. Applicants may appeal these decisions to the Magistrates' Court, or in case of a hackney carriage appeal to the Crown Court.

### **Exceptions to Age Requirement**

- 3.16 Special Event Vehicles are exempt from the general age policy and fall into the following categories:
- 3.16.1 Executive Vehicles presented for licensing for the first time must not be older than 3 years on the day the application is received.
  - 3.16.2 American Stretch Limousines presented for licensing for the first time must not be older than 7 years on the day the application is received.
  - 3.16.3 Historic Vehicles presented for licensing for the first time must not be constructed after 1<sup>st</sup> January 1973. Note: In accordance with DVLA taxation class for Historic Vehicles.
- 3.17 Vehicles not meeting the above criteria may be granted by authorised officers of the Borough Council using delegated authority provided the vehicle is considered 'exceptional' (see Condition 3.13 above).

### **Vehicle Specifications**

- 3.18 The vehicle shall have four side opening doors (designed for the purpose of permitting persons access to/from the interior) - any lift-up tailgate shall not be included; or a vehicle shall have three side opening doors (designed for the purpose of permitting persons access to/from the interior) and two rear opening doors (designed for the purpose of permitting persons access to/from the interior).
- 3.19 Any vehicle's suitability for licensing will also be determined by the positioning of its seating, fittings and fixtures for the ingress and egress of passengers and their safety.
- 3.20 Other than a vehicle classed as a special event vehicle the vehicle must be right-hand drive.
- 3.21 The vehicle must have European Community Whole Vehicle Type Approval (ECWVTA) and must show category M1 on the V5C/logbook.
- 3.22 If the requirements in Condition 3.21 above cannot be satisfied, or if the vehicle has been altered from the original manufacturers specification, then a Driver and Vehicle Standards Agency (DVSA) Individual Vehicle approval (IVA) or Voluntary Individual Vehicle Approval (VIVA) inspection must be undertaken and a satisfactory report produced.



- 3.23 In the case of a Private Hire vehicle its appearance must not lead people to believe it is a Hackney Carriage Vehicle.
- 3.24 No vehicle will be licensed unless it can accommodate at least four passengers.
- 3.25 The vehicle must have seats with a minimum width of not less than 400mm per person.
- 3.26 The vehicle shall be fitted with appropriate seatbelts to the front and rear seats of the vehicle.
- 3.27 All wheelchair accessible vehicles shall be properly equipped with properly mounted fittings for the safe securing of a wheelchair and a passenger seated in it, when carried in the vehicle.
- 3.28 If a mechanical hoist is fitted to the vehicle this will be required to be inspected annually by the manufacturer or his approved agent and a certificate produced to that effect.
- 3.29 Estate versions of saloon vehicles fitted with seats in the rear luggage compartment will be licensed for a maximum of 4 passengers.

#### **Roof /Boot Racks & Bullbars**

- 3.30 No roof, boot racks or bullbars may be fitted to Licensed Hackney Carriages during the currency of the licence.

#### **Carriage of Portable Oxygen Tanks**

- 3.31 Hackney carriage/private hire vehicle drivers will accept the carriage of portable oxygen tanks for passengers that require their usage for medical purposes.

#### **Vehicle Test Standards**

##### **Vehicle Testing**

- 3.32 No vehicle shall be first licensed or re-licensed unless the vehicle has passed the vehicle inspection at one of the Borough Council's approved testing stations. All Hackney Carriage & Private Hire vehicles after 5 years (date as shown on DVLA V5 registration document) shall have a vehicle compliance test at an approved Vehicle Testing Station every 6 months. In addition, an authorised officer of the Borough Council may inspect all vehicles for first licensing and upon renewal.
- 3.33 The Borough Council will not grant/renew a vehicle licence unless the person examining it (on behalf of the Borough Council) has confirmed that it meets the standards specified in The Borough Council's Hackney Carriage & Private Hire Vehicle Compliance Testing Standards Code of Practice (See Annex C) and, at the same time, the vehicle has been



certified roadworthy to MOT standard and has a current MOT certificate. Vehicles of a class that are not subject to 'EU Type approval' and are being tested for the first time will be additionally tested to ensure tyres and any other aspect of the vehicle are safe and mechanically sound for the benefit of passenger.

- 3.34 Costs of such testing is payable by the person wishing to licence the vehicle. In addition the history of the vehicle may be taken into consideration when determining whether the vehicle should be licensed.
- 3.35 The 6 monthly compliance test certificate required for vehicles over 5 years old (see 3.32 above) must be produced to the Borough Council within 7 days of the date of the test. Tests can be carried out by an approved testing station up to one calendar month before the 6 monthly point of the licence.
- 3.36 A vehicle which fails an inspection/safety check during the currency of a licence with The Borough Council will have the fault(s) rectified and the vehicle re-inspected at the same testing station within 2 months of the original inspection – failure to do so will lead to the automatic revocation of the vehicle licence.
- 3.37 A vehicle may be inspected by an authorised officer of the Borough Council or a Police Officer, at any reasonable time. If the person inspecting the vehicle is not satisfied as to the fitness of the vehicle he may give written notice to the proprietor/operator to make the vehicle available for further inspection and testing at such reasonable time and place as may be specified and the vehicle licence may be suspended until the authorised officer or police officer is so satisfied. If the authorised officer or police officer is not satisfied within two months of the initial inspection the Vehicle licence shall be deemed revoked. An authorised officer or police officer may permit other persons to examine the vehicle on their behalf (e.g. VOSA).

### **Altered Vehicles**

3.38 (a) Any vehicle which has been altered from the original manufacturers specification, re-registered or has been an insurance loss (categories C and D only) shall only be considered for licensing if the vehicle has been subjected to a satisfactory IVA or VIVA test (engineers report) from the Driver and Vehicle Standards Agency (DVSA).

(b) Vehicles without a DVSA engineers report will only be considered for licensing if they have been built to the manufacturers original specification.

(c) The IVA test is appropriate for vehicles not previously registered in the UK, and a VIVA for vehicles registered in the UK to prove compliance.

(d) Category A and B write offs will not be considered fit for licensing.

## Vehicle Inspections

- 3.39 All vehicles being presented for testing at the approved Borough Council testing station shall be in clean condition to allow the tester to inspect the vehicle. The tester may refuse to test a vehicle that does not conform to this requirement.

## Exterior Bodywork and Wheel trims

- 3.40 The bodywork of the vehicle shall be in good condition and shall be as originally fitted by the manufacturer. Wheel trims must be fitted to all road wheels where part of the manufacturer's original specification.

## Vehicle Accidents / **Damage to Vehicle**

- 3.41 (a) The proprietor of a private hire/hackney carriage vehicle must report to the Borough Council (by way of a prescribed accident notification and vehicle damage form) as soon as possible or in any event within 72 hours, any accident or incident which has caused damage to the vehicle or to any other property (i.e. other vehicle, fence post etc).

(b) An example of the accident notification and vehicle damage form is attached at Annex A. Forms for completion can be obtained from the Borough Council.

(c) It is not necessary to report a stone chip or other similar very minor damage to a licensed vehicle providing no damage has been caused to a person or property, and the damage would pass a compliance test.

## First Aid and Fire Equipment

- 3.42 The following equipment shall be provided and maintained in all licensed vehicles at all times.

## Fire Extinguisher

- 3.43 To be carried in such a position as to be readily accessible and available in any emergency. The fire extinguisher should be either a 1kg dry powder or a 2 litre AFFF. Fire extinguishers must be maintained in accordance with BS5306 Part 3 i.e. they must have an annual service, a five-yearly service and refilled. These tests must be carried out by a BAFE certified engineer and new tags and seals must be placed on each extinguisher after inspection.

- 3.44 Unique identification tags will be provided for each extinguisher and must be affixed to the extinguisher at all times.

## First Aid

3.45 The first-aid kit is for self-administration only. The following contents must be presented in a suitable container marked 'First Aid' positioned so that it is readily available for use:

- 10 x medifresh antiseptic wipes or equivalent
- 1 x 7.5cm bandage
- 2 x triangular bandages
- 24 x assorted plasters
- 3 x large ambulance dressings
- 2 x eye pads and elastic to secure
- 12 x assorted safety pins
- 1 x pair scissors
- 2 x pairs disposable gloves

### **Change of Address**

3.46 A licence holder on changing address shall notify the Borough Council, in writing, of such change within 7 days.

### **Citizen Band Radios**

3.47 No citizen band radios may be fitted in any Hackney Carriage or Private Hire Vehicle whilst it is licensed.

### **Radio Scanning Devices**

3.48 No radio scanning devices of whatsoever type or sort may be fitted to, carried in or used in or in the vicinity of any Hackney Carriage or Private Hire Vehicle during the currency of the licence.

### **CCTV Cameras**

3.49 Licensed Vehicle proprietor may, subject to the written approval of the Borough Council, install and use a visible closed circuit TV surveillance camera in their vehicles which face outward and are for insurance purposes only. The camera must not record audio sound within the vehicle.

3.50 There is no requirement to display signage where outward only facing cameras are fitted.

### **Upholstery**

3.51 All upholstery shall be clean and in a well maintained condition. No tear, crack, hole or burn will be acceptable other than 'fair, wear & tear'. Upholstery includes seats, headrests, armrests, carpets and other trim.

### **Ventilation**

3.52 All vehicles shall have suitable and adequate ventilation.

## **Fittings**

- 3.53 All fittings shall be properly maintained and in good working order. Fittings include clocks, interior lights, sun blinds, door surrounds, grab handles, other equipment provided for passenger comfort and any equipment in, on or forming part of the vehicle including wheelchair ramps and securing fittings where the vehicle is to be licensed to carry wheelchair bound passengers.

## **Roof and Floor Coverings**

- 3.54 These should be clean and in good condition, with no tears or other damage.

## **LPG Conversions for existing licensed vehicles**

- 3.55 Any vehicle proprietor converting their licensed vehicle to run on Liquid Petroleum Gas (LPG) must notify the Borough Council of such change and comply with the following conditions.
- LPG systems must be fitted in accordance with LPGA Code of Practice 11.
  - That the vehicle displays on the front and rear screens, a sticker stating that the vehicle has been fitted with a LPG tank for the purpose of alerting the emergency services in the event of an accident.
  - If a doughnut tank is fitted in the spare wheel well of the boot, the spare wheel must be securely placed in a position not obstructing the entire luggage space.
  - The proprietor of the vehicle must notify DVLA Swansea of the change in fuel from petrol to both LPG and petrol.
  - The vehicle must be annually serviced by a person competent in LPG powered vehicles.

## **New applicants - Vehicles Powered by Liquid Petroleum Gas (LPG)**

- 3.56 An applicant for a licence involving a vehicle which has been converted to run on LPG will be required to produce, prior to a licence being issued, a certificate stating that the LPG system has been fitted in accordance with LPGA Code of Practice 11.
- 3.57 The vehicle will be required to undergo an annual service by a person competent in LPG powered vehicles in addition to the Borough Councils Manual of Inspection Standards.
- 3.58 If an LPG conversion involves installation of an LPG fuel tank in a vehicle's boot space (and possible relocation of the spare wheel) it shall be a requirement that an amount of space shall remain free for the storage of a reasonable amount of luggage and any spare wheel displaced as a

result must be stored in a location that does not impinge on the passenger carrying area of a vehicle.

### **Tinted Windows.**

3.59 No glass, with the exception of a tinted sun-strip along the top of the windscreen, shall be tinted to such an extent as to obscure the view of the inside of the vehicle under normal workshop lighting conditions from a distance of 4 metres. Stretched Limousines are exempt from this requirement.

### **Unfit Vehicle Notices**

3.60 Unfit Vehicle notices can be issued by Authorised Officers and Police Officers where vehicle defects give cause for concern.

3.61 Immediate Unfit Notices will be given if the vehicle appears to be unsafe to carry members of the public. Once a Notice is issued the vehicle must not be used for hire with immediate effect. The vehicle must be presented to either an officer or the Borough Councils approved testing station with the faults rectified. Only after this will the Notice be lifted and the vehicle can then be used for hire.

3.62 If the Notice is not lifted within two-months, the vehicle licence will be deemed revoked.

3.63 Deferred Notices can be issued which means the vehicle can continue to be used for the time specified and the faults rectified within a specified time. When the faults are rectified the vehicle must be presented to a Borough Council approved testing station for inspection.

### **Advertising on outside of vehicle**

3.64 The Borough Council will allow advertisements to be placed upon a vehicle subject to the following:

- The proprietor of a licensed vehicle shall not display or permit to be displayed on the vehicle any sign or advertisement whatsoever unless written permission has been obtained from the Borough Council.
- Advertising is to be limited to the back door panels of licensed vehicles only. Advertising on parts of the vehicle in addition to the back door panels may be considered but only after prior written approval of the Borough Council has been given. However, no advertising will be permitted on the windows of the vehicle.
- All advertisements shall comply with the British Code of Advertising Practice and shall be in a form acceptable to the Advertising Standards Authority. The Borough Council reserves the right to require the licensee to withdraw from display any advertisement which may be considered inaccurate, misleading, unlawful, defamatory, in bad taste or of an unacceptable standard.

- No advertisement will be permitted that relates to or advertises alcohol, nudity, gambling, smoking materials or others of a political nature.
- The same advertising must be displayed on the nearside and offside doors of vehicles.
- Any advertising may cover both back doors.
- Advertising may not be stuck over door trims. Door trims may not be removed to accommodate advertising.
- In the case of Private Hire Vehicles advertising is subject to the specific exclusion of the words "taxi", "cab" or "hire" the use of which will not be permitted.

3.65 The Borough Council reserves the right to withdraw from display any advertisement which may be considered inaccurate, misleading, unlawful, defamatory, in bad taste or of an unacceptable standard.

## **Vehicle Identification**

### **External Licence Plate**

3.66 The vehicle licence plate shall be securely fixed and displayed outside and on the rear of the vehicle and shall be clearly visible during daylight hours from a distance of not less than 5 metres. The licence plate must not obstruct any signage prescribed by the Borough Council or any lights or the vehicles registration mark. Any items such as towbars must not obstruct the licence plate.

3.67 The licence plate shall be displayed in a vertical position and firmly fixed to the outside of the vehicle at the rear. The plate must be prominently displayed as to be readily visible to members of the public and that the figures and numbers endorsed thereon are distinct and legible.

3.68 The licence plate is the property of The Borough Council to whom it must be returned within 7 days of demand if the licence is suspended, revoked or not renewed for any reason. Authorised officers are entitled to physically remove the plate from the vehicle and retain it where necessary.

### **Internal Licence**

3.69 The internal vehicle licence shall be fixed and displayed inside the front windscreen on the passenger side of the vehicle **in the bottom corner and must not be obstructed.**

### **Reporting a Lost, Damaged or Stolen Licence Plate**

3.70 The vehicle proprietor/licensee shall inform the Borough Council within 72 hours should the licence plate become lost, damaged or stolen. If lost or stolen, the matter shall be reported to the police and a relevant reference number shall be required (i.e. Crime Number or Lost Property reference).

### **List of drivers to be maintained**

3.71 The vehicle proprietor/licensee shall maintain a list of names and addresses of all persons that have use of that licensed vehicle. The list shall be made available to authorised officers upon request.

### **Trailers attached to Licensed Vehicles**

3.72 The proprietor of a licensed vehicle may attach a trailer for carrying luggage when required, subject to the completion of the relevant application, and providing that an external trailer licence plate is affixed to the rear of the trailer. The licence plate must be the same as the vehicle licence plate, with the addition of a trailer symbol.

3.72.1 Trailers can not be used by Hackney Carriage vehicles when plying for hire on a Hackney Carriage Stand.

3.72.2 The trailer must at all times comply with all Road Traffic legislation requirements, in particular those laid down in the Road Vehicles (Construction and use) Regulations 1986

3.73 Trailers must comply with the following standards:

- (i) Unbraked trailers shall be less than 750kg gross weight
- (ii) Trailers over 750kg gross weight shall be braked acting on at least 2 road wheels.
- (iii) The towing vehicle must have a kerb weight at least twice the gross weight of the trailer.
- (iv) A suitable lid or other approved means of enclosure shall be fitted to secure the contents within the trailer whenever in use.
- (v) The maximum permissible length of the trailer shall be 7 metres including the drawbar and coupling.
- (vi) The width of the trailer shall not be greater than the towing vehicle subject to no trailer being wider than 2.3 metres.
- (vii) The maximum length for braked axle trailers is 5.54 metres.

## **4.0 Hackney Carriage Vehicles**

4.1 The following are conditions attached to the hackney carriage vehicle licence. These conditions are additional to the requirements imposed upon proprietors by the Town Police Clauses Act 1847 and the Local Government (Miscellaneous Provisions) Act 1976. Breach of any of these conditions may lead to suspension or revocation of the licence and/or prosecution. These conditions are equally applicable when the hackney carriage is being used for private hire purposes.

## Wheelchair Accessible Vehicle Specifications

### Restriction on Numbers of Licensed Vehicles

4.2 The Borough Council does not restrict the number of hackney carriage licences that it issues. Licence numbers 1 to 52 may be saloon vehicles but any additional hackney licenses issued, i.e 53 onwards must be wheelchair accessible and comply with the Borough Council's age policy.

### First Registration

4.3 Any additional Hackney Carriage Vehicle licenses issued must be wheelchair accessible (plate 53 onwards) and comply with condition 3.13.

### Wheelchair Occupant Space

4.4 A wheelchair space shall not be less than:

- 1200mm measured in the longitudinal plane of the vehicle
- 750mm measured in the transverse plane of the vehicle
- 1300mm measured vertically from any part of the floor of the wheelchair space.

A wheelchair space shall allow the carriage of a wheelchair and a wheelchair user.

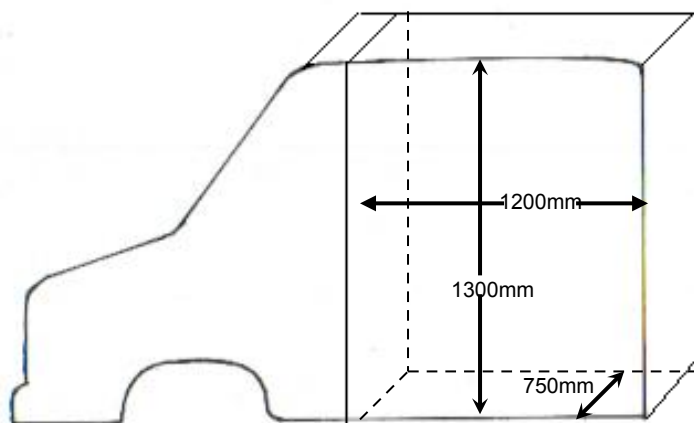

### Lifts/Ramps

4.5 Access to the vehicle must be possible from the road or pavement either by a lift or ramp. Any power-operated device must be capable of manual operation in the event of a power failure. The boarding device must have a safe working load of 300kg and operate under normal loading conditions without undue deflection.



## **Ramps**

- 4.6 A ramp should be of slip resistance material and at least 750mm in width. The ramp should be capable of being deployed both onto the road and onto a 125mm high kerb. The ramp when deployed should be securely located at the point of entry to the vehicle. For side loading the ramp when deployed to the pavement should not exceed a slope of 1:4. For rear loading the ramp when deployed to the road should not exceed 1:4. When not in use the ramp should be securely stored in such a manner as not to block any of the vehicle doors and not to present a hazard to the vehicle occupants.

## **Lifts**

- 4.7 The lift platform must be not less than 750mm in width and not less than 1200mm in length. The ramp should be equipped with a device to prevent the wheelchair rolling off and should operate at a vertical speed of less than 0.15m/s.

## **Wheelchair securing mechanism anchorage**

- 4.8 A 4 point anchorage system must be fitted, comprising two for attachment at the front of the wheelchair and two at the rear of the wheelchair, in accordance with ISO 10542-2.

## **Wheelchair securing mechanism**

- 4.9 A suitable securing mechanism must be provided to secure the wheelchair in position and the wheelchair should be locked in place before the journey commences. The occupant of the wheelchair must be provided with an occupant restraining system (seatbelt).

## **Insurance**

- 4.10 The proprietor shall keep in force, in relation to the use of the hackney carriage, a policy of insurance in respect of public hire and complying with the provisions of Section 145 of Part VIA Road Traffic Act 1988 which covers third party liability both in respect of physical injury or death and in respect of damage to personal belongings. The certificate of insurance and schedule must be produced, on demand to an authorised officer of the Borough Council for inspection.
- 4.11 It shall be the responsibility of the proprietor of a hackney carriage to produce proof of continuous insurance cover in respect of public hire. The insurance proof is to be reviewed by the licensing authority within seven days of the expiry of the preceding certificate or cover note.
- 4.12 If the proprietor fails to produce a certificate of insurance cover on request he shall produce it forthwith or within seven clear days of the request to an

authorised officer of the Borough Council. Failure to comply may result in suspension of the Hackney Carriage Vehicle licence.

### **Transfer of interest in the vehicle**

- 4.13 If a proprietor of a licensed hackney carriage vehicle transfers his interest, in whole or in part, in the vehicle to any other person not specified in the vehicle licence he must notify the Borough Council within 14 days using the appropriate form. The form must be accompanied by the fee and supporting documents.

### **Taximeters**

- 4.14 All Hackney Carriage vehicles licensed or to be licensed shall have a taximeter fitted. Each taximeter shall be tested by one of the Borough Council's approved testing stations in order to establish that the meter reflects the fares prescribed in the current Hackney Carriage Fare Tariff approved by the Borough Council.
- 4.15 The taximeter shall be placed in a safe position and so far as possible so that all letters and figures on the face thereof shall be at all times plainly visible to any persons being conveyed in the carriage. For that purpose, the letter and figures shall be capable of being suitably illuminated during the period of hiring.
- 4.16 The driver of a hackney carriage shall, at the commencement of the journey, activate the meter so that the word 'Hired' is clearly visible and shall keep the meter operating until the termination of the hiring – 'Commencement of the journey' means:
- When the hirer enters the vehicle.
  - When the driver has attended at an appointed place, and has made his presence known to the hirer.
  - When the driver has presented him/herself at an appointed place at a specified time.
- 4.17 The driver of a Hackney Carriage Vehicle shall when standing or plying for hire keep the taximeter locked in the position in which no fare is recorded on the face of the taximeter and operate a sign, which shall bare the words 'For Hire' in clear legible letters.
- 4.18 Any taximeter fitted to a Hackney Carriage Vehicle, which has been adjusted or repaired shall have the taximeter retested by one of the Borough Council's approved testing stations.
- 4.19 The taximeter shall clearly display a fare not exceeding the rate or fare approved by the Borough Council.
- 4.20 The taximeter and all the fitting thereof shall be so affixed to the carriage with security seals or other appliances that it shall not be practicable for

any person to tamper with them except by breaking, damaging or permanently disabling the security seals.

### **Inspection of Vehicle and Taxi Meter**

- 4.21 A taxi meter fitted to a licensed vehicle may be inspected by an authorised officer of the Borough Council or by a Police Officer at all reasonable times.
- 4.22 If the officer or constable inspecting the vehicle is not satisfied as to the fitness of the vehicle or the accuracy of the meter, he may without prejudice to the taxi meter condition, give written notice to the proprietor to make the Hackney Carriage and/or taxi meter available for further inspection and testing at such reasonable time and place as may be specified, and the vehicle licence may be suspended until the officer or constable is satisfied as to the vehicles fitness or as to the accuracy of the taxi meter.
- 4.23 If the officer or constable is not so satisfied within two months of the initial inspection, the Hackney Carriage Licence shall be deemed revoked.

### **Roof Signs**

- 4.24 All Hackney Carriage vehicles must be fitted with roof-mounted signs.
- 4.25 Roof signs fitted upon a Hackney Carriage Vehicle must be white in colour and shall be securely fitted to the vehicle and must be of a design and shape approved by the Borough Council.
- 4.26 All Hackney Carriage Vehicle roof signs shall display the wording 'taxi' on the front. The sign shall be capable of being illuminated internally in such a manner that the word 'TAXI', is illuminated at all times when the vehicle is plying for hire, but not otherwise.
- 4.27 All wording shall be black in colour and the word 'TAXI' must be readable from a distance of 20 metres.

### **Vehicle Inspections**

- 4.28 A vehicle which fails a compliance inspection/safety check during the currency of a licence will have the fault (s) rectified and the vehicle re-inspected within 2 months of the original inspection – failure to do so will lead to the automatic revocation of the vehicle licence.
- 4.29 A Hackney Carriage may be inspected by an authorised officer of the Borough Council or a police officer, at all reasonable times. If the person inspecting the vehicle is not satisfied as to the fitness of the vehicle he may give written notice to the proprietor to make the vehicle available for further inspection and testing at such reasonable time and place as may be specified, and the vehicle licence may be suspended until the officer or police officer is so satisfied.

- 4.30 If the authorised officer or police officer is not so satisfied within two months of the initial inspection the Hackney Carriage vehicle licence shall be deemed revoked.

#### **Alteration of Vehicle**

- 4.31 During the currency of the Licence, no material alteration or change in the specification, design, condition or appearance of the vehicle shall be made without the prior written approval of the Borough Council. All vehicles must have four doors with the exception of purpose built vehicles.

#### **Passengers**

- 4.32 The proprietor or owner of a Licensed Hackney Carriage shall not permit to be conveyed in the vehicle a greater number of persons than prescribed on the licence for the vehicle.

- 4.33 The driver of a Licensed Hackney Carriage shall not, without the consent of the hirer of the vehicle, convey or permit to be conveyed any other person in the vehicle.

- 4.34 A driver shall not refuse to carry fewer persons than the number marked on the plate.

#### **Unattended Taxis**

- 4.35 No Hackney Carriage may be left on a taxi rank designated by Section 65 Local Government (Miscellaneous Provisions) Act 1976 or a Local Traffic Order without a licensed driver in attendance to take care of it whilst plying for hire.

## 5.0 Private Hire Vehicles

### Roof Signs

- 5.1 The Borough Council will not permit a Private Hire vehicle to be fitted with a roof-mounted sign of any kind.

### Vehicle Signage

- 5.2 The private hire vehicle shall not display any sign, which consists of or includes the word 'Taxi' or 'Cab' whether singular or plural, or 'Hire', or any word of a similar meaning or appearance to any of those words, whether alone or as part of another word. The only exceptions are:

5.2.1 The word 'Hire' displayed on a private hire vehicle is when the word is used in conjunction with the word 'Private' to form the term 'Private Hire'.

5.2.2 To meet the requirements of Condition 5.3 below.

- 5.3 A sign must be displayed in a prominent position on each front side door of the vehicle displaying either:

5.3.1 Borough Council logo with the wording 'Pre-Booked Only, no advance booking, no insurance', or

5.3.2 Borough Council logo and specifying the operator name, telephone number for bookings, with the wording 'Pre-Booked Only'

- 5.4 The sign must be in either of the prescribed formats (see examples below) and must be affixed to the vehicle by an authorised sign maker. Removable signs e.g. magnetic will not be permitted. The signage is only obtainable via the Borough Council's licensing team and must be fitted within 14 days of the date the signage is ready and available with the signage company.



## **Change of Use**

5.5 Once a Hackney Carriage or Private Hire vehicle has passed first registration it will not be considered as a new application if a change of use between either category is requested, or if the licence has previously lapsed and is being re-instated. This is conditional that the vehicle held a vehicle licence issued by this authority in the preceding 3 months, and that the previous licence holder makes the new application.

## **Transfer of vehicle**

5.6 If a proprietor of a private hire vehicle transfers his interest, in whole or in part, in the vehicle to any other person not specified in the vehicle licence he must notify the Borough Council within 14 days using the appropriate form. The form must be accompanied by the fee and supporting documents.

DRAFT

## 6.0 Special Event Vehicles

### Application in Writing

6.1 Any person wishing to apply for a special event vehicle licence will be required to apply in writing to the Environmental Health Manager (Commercial) stating the type of vehicle, and age, which they intend to use and the reasons why they believe that they should be considered for this vehicle category. Vehicles issued with a special event licence shall only be used for special occasions and executive business contracts. Vehicles licensed within this category shall not be used for everyday private hire use, e.g. 'school contracts' but must work under the control of a private hire operator.

### Sale of Alcohol

6.2 The licensee shall not facilitate the sale of alcohol unless there is in force an appropriate authorisation under the Licensing Act 2003 (either a premises licence or temporary event notice) permitting the sale of alcohol.

### Types of Vehicle

6.3 Special event vehicles are a type of private hire vehicle and fall into the following 4 categories:

- Executive Vehicles;
- Novelty Vehicles
- Stretched Limousines;
- Historic Vehicles

### Age Requirements

6.4 Executive Vehicles & Novelty Vehicles presented for licensing for the first time should not normally be older than 3 years on the day the application is received.

6.5 Stretch Limousines presented for licensing for the first time should not normally be older than 7 years on the day the application is received.

6.6 Historic Vehicles presented for licensing for the first time must not have been constructed after 1<sup>st</sup> January 1973. Note: This is in accordance with DVLA taxation class for Historic Vehicles.

### Licence Plate

6.7 The vehicle licence plate will be required to be fixed to the inside of the boot lid on the vehicle.

### Communication Equipment

6.8 No vehicle shall be fitted with a two-way radio system.

## **Dress Code**

6.9 Drivers of special event vehicles will be required to observe a 'smart casual' dress code e.g. no jeans, no t-shirts, no sportswear etc. A minimum acceptable standard for men includes shoes, trousers and a formal shirt (i.e. with collar). For women a minimum acceptable standard includes shoes, trousers or skirt and a blouse or jumper.

## **Minimum Booking Fee**

6.10 Vehicles shall not be offered for hire for less than a £30 minimum-booking fee. A receipt must be given to the customer in all cases, unless covered by a contract and receipts and contracts should be available to authorised officers of the Borough Council for inspection;

## **Stretched Limousines**

6.11 A "stretched limousine", is a saloon type vehicle that has undergone an increase in length by extending the wheelbase after manufacture. An "American stretched limousine" is a stretched limousine imported from the USA and typically will have been manufactured originally by Lincoln (Ford) or Cadillac.

6.12 The purpose of this Policy and subsequent conditions is to protect public safety. The conditions will apply in addition to the Authority's standard conditions for private hire vehicles and take account of the fact that stretched limousines will:

- travel generally at slower speeds than normal taxis;
- not normally overtake other vehicles;
- be easily recognisable by the hirer;
- be heavier and considerably longer than standard cars;
- be adapted or converted by someone other than the original manufacturer.

6.13 For the purposes of calculating the seating capacity of a vehicle the minimum width of a passenger seat is 400mm (16 inches). In the case of an 'L' shaped seat, sufficient space must be made available in the corner to prevent the passenger on one side of the corner encroaching on the passenger on the other side.

6.14 In the case of a stretched limousine, or an American stretched limousine, where the vehicle has been constructed or adapted to seat up to 8 passengers, originals of the following documentation will be required by the Borough Council before an initial application for a vehicle licence can be considered:



- Completed importation documentation where applicable and individual vehicle approval (IVA) or Voluntary Individual Vehicle Approval (VIVA) certificate.
- Proof the 'stretch' was performed by the manufacturer or by a Coachbuilder approved by the vehicle manufacturer i.e. American Limousines must have been built by an approved coachbuilder under the QVM programme for Ford Vehicles or the CMC programme for Cadillac Vehicles.
- DVLA Registration Document (V5).
- Valid Certificate of Insurance, with cover for hire and reward.
- Current MOT certificate issued by an approved Testing Station.
- Where applicable, an installation certificate from a Liquefied Petroleum Gas Association (LPGA) Approved UK Vehicle Conversion Company, in the case of vehicles converted to run on LPG.
- Valid Road Vehicle Excise licence.

### **Replacement Parts**

6.15 Any replacement parts fitted to stretch limousine vehicles must meet the approved standards of the stretched specifications i.e. tyres will not only have to meet the size specifications, but must also meet the weight specification.

### **Window Tints**

6.16 Stretch limousines are exempt from Condition 3.59 regarding tinted windows fitted to the side and rear window glass of the vehicle. The driver and passenger front side window glass and the front windscreen (cockpit area) must comply with Condition 3.59.

### **.Private Hire Operator – Additional Requirement**

6.17 Special event vehicles must be specifically requested by the customer and it is not for the operator to determine which class of vehicle should be assigned to the booking. In addition to the private hire operator records required under paragraph 8, operators of special event vehicles are to maintain a record of the nature of the special event i.e. why the customer requested a special event vehicle.

## **7.0 Combined Hackney Carriage & Private Hire Driver's Licences**

7.1 Before a person is licensed, or renews a licence, as a licensed driver the following requirements shall be met:

7.1.1 All applicants/Drivers must be in possession of a full driving licence issued by the DVLA or a licence from an EEA or EU state and that licence must have been in place, for at least, the preceding 12 months.

7.1.2 Any applicant must be medically examined by a qualified medical practitioner at the practice where the applicant is registered and must be considered fit enough to meet at least the standards required for the grant of a Group II driving licence as recommended by the Driver Vehicle Licensing Agency. Medical certificates supplied upon first registration will be accepted if dated up to 6 months before the date of initial application.

7.1.3 An enquiry shall be made of the DVLA to establish the validity of any applicant's UK driving licence and any motoring convictions recorded against him/her in order to confirm that the applicant is a fit and proper person to hold, or continue to hold, a licence. The applicant will be required to authorise the Borough Council to make such enquiries.

7.1.4 An applicant's criminal record shall be obtained via the Disclosure and Barring Service at "enhanced" level in order to confirm that the applicant is a fit and proper person to hold a licence. The applicant will be required to complete the necessary forms for the purpose. If a Disclosure and Barring Service check is not available, the applicant must provide a certificate of good citizenship or equivalent from every country where the applicant has been resident.

7.1.5 Any applicant must make a declaration (by means of a form or questionnaire provided for the purpose) as to any criminal or motoring convictions recorded or pending against him/her in order to confirm that the applicant is a fit and proper person to hold a licence.

7.2 The DVLA driving licence must cover the appropriate category for the vehicle being driven.

7.3 All holders of a Combined Driver's licence shall be required to take and pass a medical examination at age 45, then every five years after the age of 45 and then annually from the age of 65 years. A driver under the age of 65 with a controlled medical condition may also be required to undergo a full medical annually or at any other time that may be prescribed by a medical practitioner. An authorised officer of the Borough Council may, upon reasonable request ask for a driver to complete a medical at any time.

- 7.4 If a medical certificate is not produced when requested, the Borough Council may consider suspension/revocation of a Drivers licence. If there is a change in a Drivers medical fitness to drive a vehicle, they must notify the Licensing Team as soon as possible or no longer than 72 hours after the change in circumstances.
- 7.5 In relation to the consideration of convictions and cautions recorded against persons the Borough Council has adopted the policy set out in Annex B (Guidelines relating to the relevance of convictions).
- 7.6 A Combined Driver's Licence shall be valid for a maximum term of three years (unless a shorter period is appropriate).
- 7.7 If a Driver accrues 9 or more points in a 3 year period on his/her DVLA driving licence, they will be required to appear before a Panel of the Licensing & Appeals Board in order for their continued suitability to hold a driver's licence to be assessed.
- 7.8 Any driver who receives, during the currency of their licence, a conviction for drink driving may automatically have their licence suspended by an Authorised Officer and will be required to appear before a Panel of the Licensing & Appeals Board for consideration of revocation of their licence.
- 7.9 The driver of a private hire vehicle while driving or in charge of such a vehicle shall not:
- 7.9.1 tout or solicit or cause or procure any other person to tout or solicit on a road or other public place any person to hire or to be carried for hire in any vehicle;
  - 7.9.2 ply for hire by offering a vehicle for immediate hire while they or that vehicle are on a road or other public place;
  - 7.9.3 accept an offer for the immediate hire of a vehicle while they or that vehicle are on a road or other public place except where the offer is first communicated to the driver in person by telephone or vehicle radio without him / her in any way procuring the offer.
  - 7.9.4 In this condition "road" means any highway and any other road to which the public has access and includes bridges over which a road passes.
- 7.10 When hired to drive to a particular destination, a driver shall (subject to any directions given by the hirer) proceed to that destination by the shortest available route.

### **Conduct of Driver**

- 7.11 The driver shall at all times:
- 7.11.1 carry a reasonable quantity of luggage when requested by any person hiring or seeking to hire a vehicle, and afford all

reasonable assistance in loading and unloading passengers' luggage.

- 7.11.2 be clean and respectable in his/her dress and person and behave in a civil and orderly manner.
- 7.11.3 take all reasonable steps to ensure the safety of passengers conveyed in, entering or alighting from the vehicle driven by him/her.
- 7.11.4 not without the express consent of the hirer play any radio or sound reproducing instrument or equipment in the vehicle other than for the purpose of sending or receiving messages in connection with the operation of the vehicle.
- 7.11.5 not cause or permit the noise emitted by any radio or other previously mentioned equipment in the vehicle which he/she is driving to be a source of nuisance or annoyance to any person, whether inside or outside the vehicle.
- 7.11.6 when collecting passengers the driver will not beep the vehicle's horn but shall make his / her arrival known in person.

#### **Change of Address**

- 7.12 The driver shall notify The Borough Council in writing of any change of his/her address during the period of the licence within seven days of the change taking place.

#### **Change of Operator**

- 7.13 The driver shall notify the Borough Council in writing of any change in the private hire operator he/she is working under the control of within 7 days of the change taking place.

#### **Convictions, Cautions, Driving Offences & Charges**

- 7.14 The driver shall notify the Borough Council in writing if he/she receives any summons, charge, conviction, caution, formal or informal notice, County Court Judgement or fixed penalty notice within seven days of receiving such. The written notification should include the following details:

- Offence / alleged offence;
- Date, place & time of offence/alleged offence;
- Whether acting as a hackney/private hire;
- If motoring offence:
  - whether paying passengers carried;
  - speed or alleged speed;
  - speed limit for road;
  - Punishment e.g. amount of fine, number of penalty points issued etc.
  - whether speed awareness course undertaken

- 7.15 Depending on the circumstances or the number of penalty points accrued on their DVLA driver's licence, drivers may be referred to a Panel of the Licensing & Appeals Board. In doing so, the Panel must have regard to all convictions, police cautions, charges, driving convictions, complaints of unacceptable conduct/behaviour, breach of licence conditions and other convictions obtained during the course of a Licence.
- 7.16 Drivers should be aware that if they fail to comply with this requirement it may prevent the Borough Council from renewing their driver's licence under delegated authority.
- 7.17 In the event of a disqualification from driving, a driver shall immediately inform the Borough Council and return their driver's badge.

### **Badges**

- 7.18 The driver shall at all times, whilst in charge of a licensed vehicle, wear their badge on their person where it is clearly visible.
- 7.19 A driver shall not damage or deface a driver's badge nor allow any other person to do so.

### **Driving licence**

- 7.20 A driver shall produce their DVLA driving licence for inspection by an authorised officer annually and at any point during the period of the licence (within 7 days of request).

### **Prompt Attendance**

- 7.21 The driver of a vehicle shall, if he/she is aware that the vehicle has been hired to be in attendance at an appointed time and place or he/she has otherwise been instructed by the operator or proprietor of the vehicle to be in attendance at an appointed time and place (unless delayed or prevented by sufficient cause) punctually attend at that appointed time and place.

### **Passengers**

- 7.22 The driver shall not convey or permit to be conveyed in a vehicle a greater number of persons than that prescribed in the licence for the vehicle.
- 7.23 The driver shall not without the consent of the hirer of a vehicle convey or permit to be conveyed any other person in that vehicle.
- 7.24 The driver, who shall knowingly convey in a vehicle the dead body of any person, shall immediately thereafter notify the fact to the Licensing Team.
- 7.25 No driver without reasonable excuse shall refuse to carry or refuse assistance to any person with a disability or refuse to carry an assistance dog (without the appropriate exemption certificate).
- 7.26 No extra fee may be charged for carrying an assistance dog or wheelchair.

### **Lost Property / Misplaced Articles**

- 7.27 The driver shall immediately after the termination of any hiring of a vehicle or as soon as practicable thereafter carefully search the vehicle for any property which may have been accidentally left there.
- 7.28 If any property accidentally left in a vehicle by any person who may have been conveyed therein is found by or handed to the driver, it shall be taken as soon as possible and in any event within twenty-four hours (if not claimed by or on behalf of its owner) to a convenient police station and left in the custody of the officer in charge after obtaining a receipt for it.

### **Animals**

- 7.29 The driver shall not convey in a vehicle any animal belonging to or in the custody of himself or the proprietor or operator of the vehicle.
- 7.30 The driver shall ensure that any animal belonging to or in the custody of any passenger is conveyed in the rear of the vehicle except that an assistance dog accompanying a disabled person may sit in the front of the vehicle provided that the animal is properly trained to sit in the foot well of the vehicle with the disabled passenger.

### **Breakdowns**

- 7.31 In the event of a breakdown during a hiring, the driver shall ensure that alternative arrangements are made for passengers to continue their journey.

### **Fare to be demanded**

- 7.32 The driver shall not demand from any hirer of a vehicle a fare in excess of any previously agreed for that hiring between the hirer and the operator.

### **Written Receipts**

- 7.33 The driver shall if requested by the hirer of a vehicle provide him with a written receipt for the fare paid.

### **Passenger Transport Badge Holders**

- 7.34 If a licensed driver holds a badge with a County Council to carry passengers on school or other contracts, and that badge is suspended or revoked by the County Council, the driver shall notify the Council, in writing, within 72 hours.

### **Smoking and Electronic Cigarettes**

- 7.35 The driver must not smoke in a licensed vehicle at any time.
- 7.36 The use of Electronic Cigarettes (e-cigs), Personal Vaporizers (PV) and Electronic Nicotine Delivery Systems (ENDS) is prohibited only whilst carrying fare paying passengers.

## **Failure to provide Information**

7.37 It is the driver's responsibility to provide the following information throughout the term of their licence:

- 7.37.1 DBS check every 3 years.
- 7.37.2 Annual DVLA check.
- 7.37.3 Medical Certificate in accordance with condition 2.10.
- 7.37.4 Annual disclosure of convictions

Failure to provide this information throughout the term of the licence may result in the suspension of the driver's license by officers under delegated authority.

## **Penalties**

7.38 The Local Government (Miscellaneous Provisions) Act 1976 provides that any person who acts in contravention of the provisions of Part II of the Act shall be guilty of an offence and liable on summary conviction to a fine. In addition to such action, whether or not resulting in criminal proceedings being taken, may lead to the suspension or revocation of an existing licence or refusal to renew such a licence.

DRAFT

## 8.0 Private Hire Operators

- 8.1 In these Conditions "The Borough Council" means The Borough Council of King's Lynn & West Norfolk and "Authorised Officer" means any officer of the Borough Council authorised in writing for the purposes of these conditions. An "operator" means the holder of a private hire operator licence issued by the Borough Council.
- 8.2 A Private Hire Operators Licence shall be valid for a maximum period of five years (unless a shorter period is appropriate). The Borough Council will only grant operators licences to operators operating from an address within the area of the Borough Council's District.
- 8.3 The applicant for the grant of a new licence will need to obtain a criminal records disclosure to enhanced level as an aid to establishing if an applicant is a suitable person to hold an operator's licence. If a Combined Drivers Licence is held an additional Criminal check will not be necessary unless the DBS Disclosure is out of date (i.e. older than 3 years).
- 8.4 The applicant must make a declaration (by means of a form or questionnaire provided for the purpose) as to any criminal or motoring convictions recorded or pending against him/her in order to confirm that the applicant is a fit and proper person to hold a licence.
- 8.5 An Operator must not include in his trading title any reference to "taxi" or "cab" unless he/she is also the proprietor of a hackney carriage vehicle.
- 8.6 An Operator must ensure that all vehicles and drivers working for them are licensed by The Borough Council.
- 8.7 When a new driver begins to work under the control of an operator, and when an existing driver leaves, the operator must inform the Borough Council in writing of that change within 7 days.
- 8.8 An Operator must keep records of bookings and produce these to an authorised officer or police officer on request. The content of these will be as prescribed by the Borough Council.
- 8.9 The Operators licence must be produced on request of an authorised officer or police officer on request.
- 8.10 An operator must, if possible, accept a booking for a Private Hire vehicle if the booking is requested by or on behalf of a disabled person, or a person who wishes a disabled person to accompany him/her.
- 8.11 An operator cannot make an additional charge for the carriage of an assistance dog.
- 8.12 An Operator shall record details of every private hire booking made by him / her. The following information shall be recorded in an easily retrievable method (e.g. computer database or page numbered log) before the commencement of each journey, and shall include the following:



- the date and time of each booking;
  - how the booking was received, i.e. telephone or personal call;
  - the time of pick-up;
  - where journey was from and to;
  - the name, address and contact telephone number of the hirer;
  - the private hire vehicle licence plate number of the vehicle allocated the booking;
  - the name of the driver allocated the booking.
- 8.13 In addition to the requirement of Condition 8.12 above, an operator of a special event vehicle must also record the nature of the special event i.e. why was a special event vehicle booked
- 8.14 The records shall be kept for a period of three years, or such longer period as is required by an Authorised Officer of the Borough Council.
- 8.15 The records shall be produced, on request, to any Police Officer or Authorised Officer of the Borough Council.
- 8.16 An Operator shall maintain at his premises details of all vehicles operated by him, which shall include the following:
- the Private Hire licence plate number;
  - the vehicle registration number;
  - the name and address of the proprietor of the vehicle;
  - the name(s) and address(es) of the driver(s) of the vehicles(s);
  - the badge number(s) of the driver(s).
- The above records shall be produced on request to any Authorised Officer of the Borough Council or Police Officer.
- 8.17 No operator shall invite or accept a private hire vehicle booking or control or arrange a journey to be undertaken by a private hire vehicle without first making available the charge for the hire of the vehicle to the person making the booking. The charge can be notified in writing or verbally.
- 8.18 The operator shall provide a prompt, efficient and reliable service to members of the public at all reasonable times. This includes the following:
- 8.18.1 Ensure that when a private hire vehicle has been hired to attend at an appointed time and place, the vehicle shall, unless delayed or prevented by sufficient cause, attend punctually at the appointed time and place.
  - 8.18.2 Keep clean, adequately heated, ventilated and lit any premises which the operator provides to which the public have access, whether for the purpose of booking or waiting.
  - 8.18.3 Ensure that any waiting area provided by the operator has adequate seating facilities.
  - 8.18.4 Ensure that any telephone facilities and radio equipment provided are maintained in a sound condition and that any defects are repaired promptly.

- 8.19 An Operator shall undertake to ensure that all drivers and vehicles owned, controlled or operated by them shall be licensed and comply with all the conditions of their driver's licence and / or Private Hire Vehicle licence.
- 8.20 The Equality Act 2010 makes it an offence for a private hire operator to fail or refuse to take a booking for a private hire vehicle;
- if the booking is requested by or on behalf of a disabled person, or a person who wishes a disabled person to accompany him; and
  - the reason for the failure or refusal is that the disabled person will be accompanied by his assistance dog.

This is subject to medical exemption certificates and it is also an offence for the operator to make any additional charge as a result of the need to carry an assistance dog.

### **Complaints**

- 8.21 An Operator shall maintain a log detailing any complaints received from customers. This shall be available for inspection by any authorised officer or police officer upon request. The log must provide the complainant's name/address/complaint details & any action taken against driver/vehicle proprietor.

### **Change of Address**

- 8.22 The operator shall notify the Borough Council in writing of any change of his address (including any address from which he operates or otherwise conducts his business as an operator) during the period of the licence within seven days of such change taking place.

### **Convictions**

- 8.23 The operator shall notify the Borough Council in writing if he/she receives any summons, charge, conviction, caution, formal notice or fixed penalty notice within seven days of receiving such. The written notification should include the following details:
- Offence /alleged offence;
  - Date, place & time offence/alleged offence;
  - Punishment e.g. fine, penalty points etc.
- 8.25 Depending on the circumstances or the number of penalty points accrued on their DVLA driver's licence (if held), operators may be referred to a Panel of the Licensing & Appeals Board. In doing so, the Panel must have regard to all convictions, police cautions, charges, driving convictions, complaints of unacceptable conduct/behaviour, breach of licence conditions and other convictions obtained during the course of a Licence.
- 8.26 Operators should be aware that if they fail to comply with condition 8.25 above, it may prevent the Borough Council from renewing their licence under delegated authority.
- 8.27 The Operator shall provide a suitable number of parking spaces for vehicles awaiting allocation for the conveyance of passengers. These parking spaces must be notified to the Licensing Team at the time of any

application or at any time there is a change in these arrangements. The Operator shall ensure that no vehicle, being operated by him, shall at any time park in a position where parking restrictions are in place, at that time, any breach of this condition will be contrary to Section 55 (3) of the Act.

8.28 Operators must ensure that non-licensed staff, i.e. controllers, cleaners etc behave in a civilised and appropriate manner when involved in the operation of the business. This includes discussion on social media sites.

### **Penalties**

8.29 The Local Government (Miscellaneous Provisions) Act 1976 provides that any person who acts in contravention of the provisions of Part II of the Act shall be guilty of an offence and liable on summary conviction to a fine not exceeding level 3 on the standard scale. In addition such action, whether or not resulting in criminal proceedings being taken, may lead to the suspension or revocation of an existing licence or refusal to renew such a licence.

DRAFT

## **9.0 Hackney Carriage Byelaws**

**Byelaws made under Section 68 of the Town Police Clauses Act, 1847 and Section 171 of the Public Health Act, 1875 by the Borough Council of King's Lynn & West Norfolk with respect to Hackney Carriages.**

### **Interpretation**

9.1 Throughout these byelaws "the Borough Council" means the Borough Council of King's Lynn & West Norfolk and "the district" means the Borough Council of King's Lynn & West Norfolk.

### **Provisions regulating the manner in which the number of each hackney carriage, corresponding with the number of its licence, shall be displayed**

9.2 The proprietor of a hackney carriage shall cause the number of the licence granted to him in respect of the carriage to be legibly painted or marked on the outside and inside respectively of the carriage, or on plates affixed thereto.

9.3 A proprietor or driver of a hackney carriage shall:-

- not willfully or negligently cause or suffer any such number to be concealed from public view while the carriage is standing or plying for hire;
- not cause or permit the carriage to stand or ply for hire with any such painting, marking or plate so defaced that any figure or material particular is illegible.

### **Provisions regulating how hackney carriages are to be furnished or provided**

9.4 The proprietor of a hackney carriage shall:-

- provide sufficient means by which any person in the carriage may communicate with the driver;
- cause the roof or covering to be kept watertight;
- provide any necessary windows and a means of opening and closing not less than one window on each side;
- cause the seats to be properly cushioned or covered;
- cause the floor to be provided with a proper carpet, mat, or other suitable covering;
- cause the fittings and furniture generally to be kept in a clean condition, well maintained and in every way fit for public service;
- provide means for securing luggage if the carriage is so constructed as to carry luggage;
- provide an efficient fire extinguisher which shall be carried in such a position as to be readily available for use;
- provide at least two doors for the use of persons conveyed in such carriage and a separate means of ingress and egress for the driver.
- cause the exterior of the carriage to be maintained in a clean condition.

9.5 The proprietor of a hackney carriage, except in the case of London Style taxis, shall cause the same to be provided with a sign safely affixed on the roof of the said hackney carriage and so constructed, attached and maintained as to comply with the following requirements, that is to say:

- the said sign shall clearly display to the front of the hackney carriage the word 'TAXI' and shall be kept illuminated during the hours of darkness; these being the hours between half-an-hour after sunset and half-an-hour before sunrise,.

9.6 The proprietor of a hackney carriage shall cause the same to be provided with a taximeter so constructed, attached, and maintained as to comply with the following requirements, that is to say:

- the taximeter shall be fitted with a key, flag or other device the turning of which will bring the machinery of the taximeter into action and cause the word "HIRED" to appear on the face of the taximeter;
- such key, flag, or other device shall be capable of being locked in such a position that the machinery of the taximeter is not in action and that no fare is recorded on the face of the taximeter;
- when the machinery of the taximeter is in action there shall be recorded on the face of the taximeter in clearly legible figures a fare not exceeding the rate or fare which the proprietor or driver is entitled to demand and take for the hire of the carriage by distance in pursuance of the byelaw in that behalf;
- the word "FARE" shall be printed on the face of the taximeter in plain letters so as clearly to apply to the fare recorded thereon;
- the taximeter shall be so placed that all letters and figures on the face thereof are at all times plainly visible to any person being conveyed in the carriage, and for that purpose the letters and figures shall be capable of being suitably illuminated during any period of hiring;
- the taximeter and all the fittings thereof shall be so affixed to the carriage with seals or other appliances that it shall not be practicable for any person to tamper with them except by breaking damaging or permanently displaying the seals or other appliances.

**Provisions regulating the conduct of the proprietors and drivers of hackney carriages plying within the district in their several employments, and determining whether such drivers shall wear any and what badges**

9.7 The driver of a hackney carriage provided with a taximeter shall:-

- when standing or plying for hire, keep the key, flag or other device fitted in pursuance of the byelaw in that behalf locked in the position in which no fare is recorded on the face of the taximeter;
- before beginning a journey for which a fare is charged for distance and time bring the machinery of the taximeter into action by moving the said key, flag or other device so that the word "HIRED" is legible on the face of the taximeter and keep the machinery of the taximeter in action until the termination of the hiring;
- cause the dial of the taximeter to be kept properly illuminated throughout any part of a hiring which is during the hours of darkness as defined for the purposes of the Road Traffic Act, 1972 and also at any other time at the request of the hirer.

9.8 A proprietor or driver of a hackney carriage shall not tamper with or permit any person to tamper with any taximeter with which the carriage is provided, with the fittings thereof, or with the seals affixed thereto.

9.9 Every proprietor or driver of a hackney carriage shall, at all times, when standing, plying, or driving for hire, conduct himself in an orderly manner, and with civility and propriety towards every person seeking to hire, or hiring, or being conveyed in such a carriage shall comply with every

reasonable requirement of any person hiring or being conveyed in such carriage.

9.10 The driver of a hackney carriage shall, when plying for hire in any street and not actually hired:

- proceed with reasonable speed to one of the stands fixed by the byelaw in that behalf;
- if a stand, at the time of his arrival, is occupied by the full number of carriages authorised to occupy it, proceed to another stand;
- on arriving at a stand not already occupied by the full number of carriages authorised to occupy it, station the carriage immediately behind the carriage or carriages on the stand and so as to face in the same direction;
- from time to time when any other carriage immediately in front is driven off or moved forward cause his carriage to be moved forward so as to fill the place previously occupied by the carriage driven off or moved forward.

9.11 A proprietor or driver of a hackney carriage, when standing or plying for hire shall not, by calling out or otherwise, importune any person to hire such carriage and shall not make use of the services of any other person for the purpose.

9.12 The driver of a hackney carriage shall take all reasonable precautions to ensure the safety of persons conveyed in or entering or alighting from the vehicle.

9.13 The proprietor or driver of a hackney carriage who has agreed or has been hired to be in attendance with the carriage at an appointed time and place shall, unless delayed or prevented by some sufficient cause, punctually attend with such carriage at such appointed time and place.

9.14 The driver of a hackney carriage when hired to drive to any particular destination shall, subject to any directions given by the hirer, proceed to that destination by the shortest available route.

9.15 A proprietor or driver of a hackney carriage shall not convey or permit to be conveyed in such carriage, any greater number of persons than the number of persons specified on the licence for such carriage issued by the Borough Council.

9.16 If a badge has been provided by the Borough Council and delivered to the driver of a hackney carriage, he shall when standing, plying or driving for hire wear that badge in such position and manner as to be plainly and distinctly visible.

9.17 The driver of a hackney carriage so constructed as to carry luggage shall, when requested by any person hiring or seeking to hire the carriage:

- convey a reasonable quantity of luggage;
- afford reasonable assistance in loading and unloading;
- afford reasonable assistance in removing it to or from the entrance of any house, station or place at which he may take up or set down such person.

- 9.18 Every proprietor or driver of a hackney carriage, who shall knowingly convey in the carriage the dead body of any person shall, immediately notify the fact to the Executive Director, Environmental Health & Housing.

**Provisions fixing the rate of fare to be paid for hackney carriages within the district and securing the due publication of fares**

- 9.19 The proprietor or driver of a hackney carriage shall be entitled to demand and take for the hire of the carriage the rate or fare prescribed by the Borough Council, the rate or fare being calculated by distance unless the hirer expresses at the commencement of the hiring his desire to engage by time.
- 9.20 Provided always that where a hackney carriage shall be hired by distance the proprietor or driver thereof shall not be entitled to demand and take a fare greater than that recorded on the face of the taximeter, save for any extra charges authorized by the Borough Council which it may not be possible to record on the face of the taximeter.
- 9.21 the proprietor of a hackney carriage shall cause a statement of the fares fixed by the Borough Council resolution in that behalf to be exhibited inside the carriage, in clearly distinguishable letters and figures.
- 9.22 The proprietor or driver of a hackney carriage bearing a statement of fares in accordance with this byelaw shall not willfully or negligently cause or suffer the letters or figures in the statement to be concealed or rendered illegible at any time while the carriage is plying or being used for hire.

**Provisions securing the safe custody and re-delivery of any property accidentally left in hackney carriages and fixing the charges to be made in respect thereof**

- 9.23 The proprietor or driver of a hackney carriage shall immediately after the termination of any hiring or as soon as practicable thereafter carefully search the carriage for any property which may have been accidentally left therein.
- 9.24 The proprietor or driver of a hackney carriage shall, if any property accidentally left therein by any person who may have been conveyed in the carriage be found by or handed to him:
- carry it as soon as possible and in any event within 48 hours, if not sooner claimed by or on behalf of its owner, to the office of the Borough Council and leave it in the custody of the officer in charge of the office on his giving a receipt for it.
  - be entitled to receive from any person to whom the property shall be re-delivered an amount equal to five pence in the pound for its estimated value (or the fare for the distance from the place of finding to the office of the Borough Council whichever be the greater) but not more than five pounds.

**Penalties**

- 9.25 Every person who shall offend against any of these byelaws shall be liable on summary conviction to a fine not exceeding one hundred pounds and in the case of a continuing offence to a further fine not exceeding five pounds for each day during which the offence continues after conviction.

## **Repeal of Byelaws**

- 9.26 The byelaws relating to hackney carriages which were made by the Borough Council of King's Lynn & West Norfolk on the 7<sup>th</sup> day of March 1983 and confirmed by the Secretary of State on the 16<sup>th</sup> day of September 1983, are hereby repealed. Given under the common seal of the King's Lynn and West Norfolk Borough Council Mayor (T.C.R Legge) & on Borough Secretary (J.H Carr) the 21<sup>st</sup> day of May 1985. The foregoing byelaw was confirmed by the Secretary of State and came into force on the 1<sup>st</sup> day of September 1985, signed by P.E Pickering, an assistant secretary in the department of transport on behalf of the secretary of state for transport, 12<sup>th</sup> August 1985.

DRAFT



## 10.0 Penalty Points System

10.1 Authorised Officers of the Borough Council can impose penalty points on drivers of private hire vehicles and hackney carriages, proprietors of vehicles and operators of private hire vehicles as shown below. This system is designed for the interest of the public as an aid to ensure continued public safety and to give the individual concerned a chance to rectify any relatively minor breaches of licence conditions without the need to resort to suspension, revocation or prosecution.

10.2 If an individual concerned accrues a total of 12 points in any 12 month period then he/she will automatically be referred to a Panel of the Licensing & Appeals Board with a request that the Panel review the individual's continued suitability to hold a licence.

10.3 The following list, whilst not exhaustive, details the circumstances in which a licence holder will be directly referred to a Panel of the Licensing & Appeals Board:

- Providing false or misleading information on licence application form, or failing to provide relevant information including any convictions imposed;
- Authorised officer refused access to operator/driver records;
- Carrying excess passengers;
- Abusive or obstructive behaviour (verbal or physical) to authorised officers of the Borough Council or police officers;
- Using a vehicle for which the licence has been suspended or revoked;
- Carrying an offensive weapon in the vehicle;
- Driver not holding a current DVLA licence;
- Nine or more penalty points on a DVLA driving licence;
- Convictions including motoring convictions for:
  - Drinking/drugs and driving;
  - Causing death by careless driving;
  - Reckless/dangerous driving;
  - Offences resulting in disqualification;
  - Disqualified from holding a licence until driving test passed.

10.4 The following list, whilst not exhaustive, details the number of penalty points that will be awarded for the infringements shown:

BC Code	Infringement	Penalty Points
PP1	Failing to notify the Licensing team, in writing of charges, summons, penalty points etc	4
PP2	Displaying any feature on a private hire vehicle which would suggest it is a taxi	4
PP3	Failure to attend the Council Offices when directed by an authorised officer.	6

BC Code	Infringement	Penalty Points
PP4	Failure to carry an assistance dog without requisite exemption	6
PP5	Failure to notify the Licensing Office of any change in medical fitness to drive.	4
PP6	Failure to notify transfer of vehicle within prescribed time limit	4
PP7	Failure to produce a valid insurance certificate/cover note within 7 days of request.	6
PP8	Failure to produce the 6 monthly MOT/Compliance check	4
PP9	Failure to report to the authority the transfer of a private hire vehicle licence or a hackney carriage proprietors licence within 14 days of transfer.	4
PP10	Failure to return vehicle licence plate within 7 days after due notice following expiry, revocation or suspension of such licence	4
PP11	Leaving a vehicle unattended on the rank.	4
PP12	Licensed vehicle not carrying a spare wheel, space saver or tyre weld that is capable of being used.	4
PP13	Private hire drivers touting	6
PP14	Private Hire Operator failing to maintain their records in the correct format.	6
PP15	Failing to notify Licensing Team of a change in private hire operator.	4
PP16	Wheelchair accessible hackney carriage fails to carry ramps for loading disabled persons wheelchair	6
PP17	Conviction for minor traffic offences e.g. obstruction, waiting in a restricted street, speeding etc.	3
PP18	Driver smoking in the vehicle	3
PP19	Failing to deal with lost property in the correct manner.	3
PP20	Failing to display fare card (hackney carriage)	3
PP21	Failing to have a Private Hire Driver or Hackney Carriage Driver badge in his possession whilst driving a licensed vehicle.	3
PP22	Failing to notify the Licensing Office in writing, of being involved in an accident within 72 hours of the accident occurring.	3
PP23	Failing to notify the Licensing team, in writing, of a change of address within 7 days.	3
PP24	Failure to display any Plates, Signs or Notices required by the Borough Council	3
PP25	Failure to display official 'no smoking' sign in vehicle	3
PP26	Licensed vehicle displaying unauthorised markings (inside or out)	3
PP27	Not having an appropriate Fire Extinguisher and/or first aid kit in the vehicle.	3
PP28	Parking/stopping contrary to authorised road markings	3
PP29	Parking/stopping with one or more wheels on the pavement	3

BC Code	Infringement	Penalty Points
PP30	Sounding the vehicle horn to announce arrival or tout for business	3
PP31	Unreasonable prolongation of journeys or any misconduct regarding the charging of fares	3
PP32	Using a mobile phone, radio hand set, eating or drinking whilst the vehicle is in motion	3
PP33	Failure to conform with the Road Traffic Act	3
PP34	Defective vehicle, i.e. bald tyre, headlight not working	4
PP35	Failure to comply with legislation pertaining to hackney carriage and private hire licensing.	3-6

DRAFT

## 11.0 Summary of Offences

### TOWN POLICE CLAUSES ACT 1847

<u>Section</u>	<u>Offence</u>
40	Giving false information on application for hackney carriage proprietor's licence
44	Failure to notify change of address of hackney carriage proprietor
45	Plying for hire without a hackney carriage proprietor's licence
47	Driving a hackney carriage without a hackney carriage driver's licence
47	Lending or parting with a hackney carriage driver's licence
47	Hackney carriage proprietor employing unlicensed driver
48	Failure by hackney carriage proprietor to hold hackney carriage driver's licence
48	Failure by hackney carriage proprietor to produce hackney carriage driver's licence
52	Failure to display hackney carriage plate
53	Refusal to take a fare
54	Charging more than the agreed fare
55	Obtaining more than the legal fare
56	Travelling less than the lawful distance for an agreed fare
57	Failing to wait after a deposit to wait has been paid
58	Charging more than the legal fare
59	Carrying other person than the hirer without consent
60	Driving a hackney carriage without proprietor's consent
60	Person allowing another to drive a hackney carriage without proprietor's consent
61	Drunken driving of hackney carriage
61	Wanton or furious driving or wilful misconduct leading to injury or danger
62	Driver leaving hackney carriage unattended
64	Hackney carriage driver obstructing other hackney carriages

## 12.0 HACKNEY CARRIAGE PROVISIONS

### LOCAL GOVERNMENT (MISCELLANEOUS PROVISIONS) ACT 1976

<b>Section</b>	<b>Offence</b>
49	Failure to notify transfer of hackney carriage proprietor's licence
50(1)	Failure to present hackney carriage for inspection as required
50(2)	Failure to inform Local Authority where hackney carriage is stored if requested
50(3)	Failure to report an accident to Local Authority
50(4)	Failure to produce hackney carriage proprietor's licence and insurance certificate
53(3)	Failure to produce hackney carriage driver's licence
57	Making false statement or withholding information to obtain hackney carriage driver's licence
58(2)	Failure to return plate after notice given after expiry, revocation or suspension of hackney carriage proprietor's licence
61(2)	Failure to surrender driver's licence after suspension, revocation or refusal to renew
64	Permitting any vehicle other than hackney carriage to wait on a hackney carriage stand
66	Charging more than the meter fare for a journey ending outside the district, without prior agreement
67	Charging more than the meter fare when hackney carriage used as private hire vehicle
69	Unnecessarily prolonging a journey
71	Interfering with a taximeter
73(1)(a)	Obstruction of authorised officer or constable
73(1)(b)	Failure to comply with requirement of authorised officer or constable
73(1)(c)	Failure to give information or assistance to authorised officer or constable

## 13.0 PRIVATE HIRE PROVISIONS

### LOCAL GOVERNMENT (MISCELLANEOUS PROVISIONS) ACT 1976

Section	Offence
46(1)(b)	Driving a private hire vehicle without a private hire driver's licence
46(1)(c)	Proprietor of a private hire vehicle using an unlicensed driver
46(1)(d)	Operating a private hire vehicle without a private hire operator's licence
46(1)(e)	Operating a vehicle as a private hire vehicle when the vehicle is not licensed as a private hire vehicle
46(1)(e)	Operating a private hire vehicle when the driver is not licensed as a private hire driver
48(6)	Failure to display private hire vehicle plate
49	Failure to notify transfer of private hire vehicle licence
50(1)	Failure to present private hire vehicle for inspection as required
50(2)	Failure to inform local authority where private hire vehicle is stored if requested
50(3)	Failure to report an accident to local authority
50(4)	Failure to produce private hire vehicle licence and insurance certificate
53(3)	Failure to produce private hire driver's licence
54(2)	Failure to wear private hire driver's badge
56(2)	Failure by private hire operator to keep records of bookings
56(3)	Failure by private hire operator to keep records of private hire vehicles operated by him
56(4)	Failure to produce private hire operator's licence on request
57	Making false statement or withholding information to obtain private hire driver's or operator's licence
58(2)	Failure to return plate after notice given after expiry, revocation or suspension of private hire vehicle licence
61(2)	Failure to surrender driver's licence after suspension, revocation or refusal to renew
67	Charging more than the meter fare when hackney carriage used as private hire vehicle
69	Unnecessarily prolonging a journey
71	Interfering with a taximeter
73(1)(a)	Obstruction of authorised officer or constable
73(1)(b)	Failure to comply with requirement of authorised officer or constable
73(1)(c)	Failure to give information or assistance to authorised officer or constable

Annex A to  
**Hackney Carriage & Private Hire Licensing Procedures & Conditions**  
**Dated 30<sup>th</sup> June 2011**



**Local Government (Miscellaneous Provisions) Act 1976 Section 50 (3) Notification**

**1. PERSON DRIVING THE VEHICLE**

Christian or Forenames:		Surname:	
Address:			
(Inc postcode)			
Telephone No:	Home:	Mobile:	
Date of Birth:		Sex (M/F):	

**2. THE VEHICLE**

Hackney Carriage or Private Hire?	
Licence Plate Number:	
Registration Number:	
Operator (if Private Hire):	

**3. THE ACCIDENT**

What date did the accident take place on?	
At what time?	
Was the accident caused by you?	
Is the vehicle considered unroadworthy and not being driven at this present time?	
*Please provide a description of how the accident happened:	
.....	
.....	
.....	
.....	
.....	

\*You will be asked to draw a diagram of the accident on the next page.

**4. SCENE OF THE ACCIDENT**

Please draw a diagram of the scene of the accident. Indicate where your vehicle was, where the other vehicle or object was. Show traffic lights or other road signs and any other vehicles or objects that you remember.

**5. VEHICLE DAMAGE / HUMAN INJURY / DAMAGE TO PROPERTY**

Please give a full description of the damage to the vehicle and any injury incurred to the driver or other person/s:

.....

.....

.....

.....

**6. WHO HAVE YOU INFORMED?**

The Police?		If so, give reference number	
Insurance Company?		If so, give claim number	
Operator?		If so, who did you inform?	

**In making this notification I confirm the information given is true to the best of my knowledge and I understand it is a criminal offence to provide false information. I also provide consent for an authorised officer of the Borough Council to contact any third party, including my insurance company regarding this accident**

Signed..... Date.....

Annex B to  
 Hackney Carriage & Private Hire Licensing Procedures & Conditions  
 Dated 30<sup>th</sup> June 2011





## 1. Introduction

1.1 The purpose of these guidelines is to provide guidance on the criteria taken into account by the Council when determining whether or not an applicant or an existing licence holder is a fit and proper person to hold a hackney carriage and/or private hire driver or operator licence.

1.2 The overriding aim of the licensing authority is to protect the safety of the public.

The licensing authority is concerned to ensure:

- That a person is a fit and proper and safe and suitable person.
- That the person does not pose a threat to the public.
- That the public are safeguarded from dishonest persons.
- The safeguarding of children, vulnerable and young persons.

1.3 This document provides guidance to any person with an interest in taxi and private hire licensing. In particular, but not exclusively:

- Applicants for Drivers' licences.
- Existing Licensed Drivers whose licences are being reviewed.
- Applicants for Private Hire Operator licenses.
- Licensing Officers.
- Members of the Licensing Panel
- Magistrates hearing appeals against Local Authority decisions.

1.4 Where Licensing Officers have delegated powers to grant licences, they will utilise these guidelines when making a decision to grant a licence. In all other cases applications for licences will be referred to the Licensing Panel. Whilst Officers and the Panel will have regard to the guidelines contained in the policy, **each case will be considered on its individual merits and, where the circumstances demand, the Panel/Officer may depart from the guidelines.**

## 2. General guidelines

2.1 There may be occasions where it is appropriate to depart from the guidelines, for example where the offence is a one-off occasion or there are mitigating circumstances or

alternatively where there are many or continuous offences which may show a pattern of offending and unfitness.

2.2 A person with a conviction for a serious offence need not be automatically barred from obtaining a licence, but would normally be expected to:

(a) Remain free of conviction for an appropriate period; and

(b) Show adequate evidence that he or she is a fit and proper person to hold a licence (the onus is on the applicant to produce such evidence). Simply remaining free of conviction may not generally be regarded as adequate evidence that a person is a fit and proper person to hold a licence.

Where an applicant has been convicted of a criminal offence, the licensing authority cannot review the merits of the conviction [Nottingham City Council v. Mohammed Farooq (1998)].

### **3. Appeals**

3.1 Any applicant refused a driver's licence on the grounds that the licensing authority is not satisfied he/she is a fit and proper person to hold such a licence has a right to appeal to the Magistrates' Court within 21 days of receipt of the notice of refusal [Local Government Miscellaneous Provisions Act 1976, s 77 (1)].

### **4. Powers**

4.1 Section 61 and Section 62 of the Local Government Miscellaneous Provisions Act 1976 allow the licensing authority to suspend, revoke or refuse to renew a licence if the applicant/licence holder has been convicted of an offence involving dishonesty, indecency, violence; failure to comply with the provisions of the Town Police Clauses Act 1847; failure to comply with the provisions of Part II of the Local Government (Miscellaneous Provisions) Act 1976; or any other reasonable cause.

4.2 The Rehabilitation of Offenders Act 1974 (Exceptions)(Amendment) Order 2002, allows the licensing authority to take into account all convictions recorded against an applicant or the holder of a private hire vehicle or hackney carriage driver's licence, whether spent or not. Therefore the licensing authority will have regard to all relevant convictions, particularly where there is a long history of offending or a recent pattern of repeat offending.

4.3 In this policy the term "disqualification" refers to the period served. In order to take account of the fact that a court may reduce the period of disqualification from driving, an applicant must provide evidence in advance to prove that the court agreed a reduction in the period of disqualification.

4.4 It should be noted that "any reasonable cause" includes conduct falling short of a criminal conviction(s).

### **5. Consideration of disclosed criminal history**

5.1 Under the provisions of Sections 51, 55, and 59, Local Government (Miscellaneous Provisions) Act 1976, the licensing authority is required to ensure that an applicant for the grant or renewal of a hackney carriage and/or a private hire vehicle drivers' licence and/or private hire vehicle operator's licence is a 'fit and proper' person to hold such a licence. However, if an applicant has any convictions, warnings, cautions or charges awaiting trial, the licensing authority will look into:

- How relevant the offence(s) are to the licence being applied for.
- How serious the offence(s) were.
- When the offence(s) were committed.
- The date of conviction.
- Circumstances of the individual concerned.
- Sentence imposed by the court.
- The applicant's age at the time of conviction.
- Whether they form part of a pattern of offending.
- Any other character check considered reasonable (e.g. personal references).
- Any other factors that might be relevant.

5.2 Existing holders of driver licences are required to notify the licensing authority in writing within seven days of receiving a driving licence endorsement, fixed penalty notice or criminal conviction (including cautions).

5.3 Applicants can discuss further what effect a caution/conviction may have on any application by contacting the Licensing Team in confidence for advice.

5.4 The licensing authority is also entitled to use other records and information that may be available to it in determining applications or an entitlement to continue holding a licence. This may include information held by the licensing authority or other licensing authorities, and information disclosed by the police or other agencies.

5.5 It is an offence for any person knowingly or recklessly to make a false declaration or to omit any material particular in giving information required by the application for a licence. Where an applicant has made a false statement or a false declaration on their application for the grant or renewal of a licence, the licence will normally be refused.

5.6 It should be noted that the determination of whether an applicant is "fit and proper" or safe and suitable includes consideration of conduct falling short of a criminal conviction.

## **6. Offences involving violence, disorder and damage to property**

6.1 Licensed drivers have close regular contact with the public. A firm line is to be taken with those who have convictions for offences involving violence, disorder or criminal damage. An application will normally be refused if the applicant has a conviction for an offence that involved the loss of life.

6.2 Any one with a conviction for an offence involving violence, disorder or damage to property will normally be expected to remain free of such convictions for a period of at least 3 years. However, given the range of the offences, consideration must be given to the nature of the conviction. A licence will not normally be granted if an applicant has more than one conviction in the last 10 years for an offence involving violence or disorder.

6.3 In the most serious cases, an application will be refused unless there are exceptional circumstances. A licence will not normally be granted where the applicant has a conviction for an offence such as:

- Murder.
- Manslaughter.
- Manslaughter or culpable homicide while driving.
- Terrorism offences.
- Or any similar offences (including attempted or conspiracy to commit) or any offences which replace the above.

6.4 An application will normally be refused if the applicant has a conviction for an offence or similar offence(s) which replace the offences below and the conviction is less than 10 years prior to the date on which the application is determined by the authority:

- Arson.
- Malicious wounding or grievous bodily harm.
- Actual bodily harm.
- Grievous bodily harm with intent.
- Robbery.
- Possession of firearm.
- Riot.
- Violent disorder.
- Any similar offences (including attempted or conspiracy to commit) or any offences which replace the above.

6.5 An application will normally be refused if the applicant has a conviction for an offence or similar offence(s) which replace the offences below and the conviction is less than 5 years prior to the date on which the application is determined by the authority:

- Common assault.
- Assault occasioning actual bodily harm.
- Affray.
- Aggravated criminal damage.
- Any racially aggravated offence.
- Resisting arrest.
- Assault police.
- Or any similar offences (including attempted or conspiracy to commit) or any offences which replace the above.

6.6 An application will normally be refused if an applicant has a conviction for an offence or similar offences(s) which replace the offences below and the conviction is less than 3 years prior to the date on which the application is determined by the authority:

- S.5 Public Order Act 1986 offence (harassment, alarm or distress).
- S.4 Public Order Act 1986 offence (fear of provocation of violence.)
- S.4A Public Order Act 1986 offence (intentional harassment, alarm or distress).

- Obstruction.
- Criminal damage.
- Or any similar offences (including attempted or conspiracy to commit) or any offences which replace the above.

6.7 A person bound over to keep the peace or be of good behaviour will not normally be granted a licence within the period of the recognisance e.g. where a person is bound over for 6 months, they will not normally be licensed within that 6 month period.

6.8 In the event of a licence being granted, a strict warning both verbally and in writing should be administered.

## **7. Possession of a weapon**

7.1 A conviction for possession of a weapon or any other weapon related offence will raise serious concerns as to the fitness of the applicant to carry the public.

7.2 Depending on the circumstances of the offence, an applicant should be free of conviction for 3 years (or at least 3 years must have passed since the completion of the sentence, whichever is longer), before a licence is granted.

## **8. Sex and indecency offences**

8.1 As licensed drivers often carry unaccompanied and vulnerable passengers, applicants with convictions for sexual offences must be closely scrutinised. Those with convictions for the more serious sexual offences will normally be refused. For other offences, applicants will be expected to show a substantial period (normally at least 15 years) free of conviction for such offences before a licence will be granted.

8.2 Unless there are exceptional circumstances, an application will normally be refused where the applicant has a conviction for an offence such as:

- Rape.
- Assault by penetration.
- Offences involving children or vulnerable adults.
- Or any similar offences (including attempted or conspiracy to commit) which replace the above.

8.3 An application will normally be refused if the applicant has a conviction for an offence listed below and the applicant has not been free of such conviction for at least 15 years.

- Sexual assault.
- Indecent assault.
- Possession of indecent photographs, child pornography etc.
- Exploitation of prostitution.
- Trafficking for sexual exploitation.
- Or any similar offences (including attempted or conspiracy to commit) or any offences which replace the above.

8.4 An application will normally be refused if the applicant has a conviction for an offence listed below and the applicant has not been free of such conviction for at least 5 years.

- Indecent exposure.
- Soliciting (kerb crawling).
- Or any similar offences (including attempted or conspiracy to commit) offences which replace the above.

8.5 In addition to the above the licensing authority will not normally grant a licence to any applicant who is currently on the Sex Offenders Register.

8.6 A licence will not normally be granted if an applicant has more than one conviction for a sex or indecency offence.

## 9. Dishonesty

9.1 A licensed PHV or taxi driver is expected to be a trustworthy person. They deal with cash transactions and valuable property may be left in their vehicles. The widespread practice of delivering unaccompanied property is indicative of the trust that business people place in licensed drivers. Moreover, it is comparatively easy for a dishonest driver to defraud the public by demanding more than the legal or agreed fare, etc. Overseas visitors can be confused by our currency and may be vulnerable to an unscrupulous driver. For all these reasons, a serious view is taken of any conviction involving dishonesty.

9.2 In general, a minimum period of 3 years free of conviction Offences involving dishonesty include:

- Theft.
- Burglary.
- Fraud.
- Benefit fraud.
- Handling or receiving stolen goods.
- Forgery.
- Conspiracy to defraud.
- Obtaining money or property by deception.
- Other deception.
- Taking a vehicle without consent.
- Or any similar offences (including attempted or conspiracy to commit) or any offences which replace the above.

## 10. Drugs

10.1 A serious view is taken of any drug related offence. The nature and quantity of the drugs, whether for personal use or supply are issues which should be considered.

10.2 An application will normally be refused where the applicant has a conviction for an offence related to the **supply of drugs** and has not been free of such conviction for 10 years.

10.3 An application will normally be refused where the applicant has more than one conviction for offences related to the **possession of drugs** and has not been free of conviction for 5 years.

10.4 An application from an applicant who has an isolated conviction for an offence related to the possession of drugs within the last 3-5 years may be granted a licence, but consideration should be given to the nature and quantity of the drugs.

10.5 If there is evidence of persistent drugs use, misuse or dependency, a specialist medical examination (in accordance with DVLA Group 2 medical standards) may be required before the licence is granted. If the applicant was an addict then they would normally be required to show evidence of 5 years free from drug taking after detoxification treatment.

## **11. Minor and Major Traffic Offences**

### Minor

11.1 Convictions for minor traffic offences e.g. obstruction, waiting in a restricted street, speeding etc. may prevent a person from being granted a hackney carriage or private hire drivers licence if they have received more than 2 motoring convictions within the last 2 years.

11.2 The accumulation of 9 or more penalty points will cast grave doubts on the suitability of the applicant and could lead to the refusal of the application.

### Major

11.3 A serious view will be taken of any conviction for a major traffic offence, this includes:

- Causing death by dangerous driving.
- Dangerous driving.
- Causing death by careless driving whilst under the influence of drink or drugs.
- Causing death by careless or inconsiderate driving.
- Careless and inconsiderate driving.
- Driving under the influence of drink or drugs etc.
- Driving whilst disqualified.
- Using a vehicle without insurance.
- Offences contrary to the taxi licensing legislation.
- Or any similar offences (including attempted or conspiracy to commit) or an offence which replaces the above.

These guidelines make specific provision for certain types of major traffic offences to reflect the seriousness of those convictions. In the case of major traffic offences where no such specific provision is made and paragraph 14 (Disqualification) does not apply, an application will normally be refused unless a period of at least 3 years free from conviction of such offences has elapsed.

## **12. Driving offences involving the loss of life**

12.1 A very serious view is to be taken of any applicant who has been convicted of a driving offence that resulted in the loss of life. A licence will not normally be granted unless the applicant is free of conviction for 7 years if he/she has a conviction for:

- Causing death by dangerous driving.
- Causing death by careless driving whilst under the influence of drink or drugs.
- Or any similar offences (including attempted or conspiracy to commit) or any offences which replace the above.

12.2 Before a licence is granted, an applicant should be free of conviction for 3 years, if he/she has a conviction for:

- Causing death by careless driving.
- Causing death by driving: unlicensed, disqualified or uninsured drivers.
- Or any similar offences (including attempted or conspiracy to commit) or any offences which replace the above.

### **13. Drink driving/driving under the influence of drugs**

13.1 As licensees are professional vocational drivers, a serious view is taken of convictions for driving, or being in charge of a vehicle while under the influence of drink or drugs.

13.2 An isolated incident would not necessarily debar an applicant from proceeding on the restoration of his DVLA driving licence but he should be warned as to the significant risk to his licence status in the event of re-offending and he must comply with the rehabilitation period below.

13.3 More than one conviction for these offences raises significant doubts as to the applicant's fitness to drive the public.

13.4 At least 3 years free of conviction, after the restoration of the driving licence following a drink drive conviction should elapse before an application will be considered. If there is any suggestion that the applicant is alcohol or drug dependent, a satisfactory special medical report must be provided before the application can be allowed to proceed.

### **14. Disqualification**

14.1 Where an applicant has been disqualified from driving following a conviction for a major traffic offence and no specific provision is made above regarding the appropriate rehabilitation period, the application will generally be refused unless a period of between 3 and 5 years free from conviction has elapsed from the restoration of the DVLA licence.

14.2 Where convictions for a number of minor traffic offences have resulted in the applicant being disqualified from driving for a period of time this will normally be taken as reflecting seriously on the applicant's driving standard. Generally, a period of 12 months free from conviction must have elapsed from the restoration of the DVLA licence.



14.3 In "totting-up" cases where disqualification is considered by the court, even if the court does not disqualify (e.g. because of exceptional circumstances) a driver, the Council is likely to refuse a hackney carriage or private hire driver's licence because different criteria apply and an applicant will normally be expected to show a period of 12 months free from conviction from the date the court made its finding of exceptional circumstances justifying the non-disqualification.

14.4 Any period of disqualification will lead to the suspension/ revocation of a licence.

## **15. Insurance offences**

15.1 A serious view will be taken of convictions of driving or being in charge of a vehicle without insurance. An isolated incident in the past will not necessarily prevent a licence being granted provided he/she has been free of such conviction for 3 years; however a strict warning should be given as to future behaviour. More than one conviction for these offences would normally prevent a licence being granted or renewed.

15.2 An operator found guilty of aiding and abetting the driving of passengers for hire and reward whilst without insurance will have his operators' licence revoked immediately and prevented from holding a licence for 3 years.

## **16. Cautions**

16.1 Admission of guilt is required before a caution can be issued. Every case will be considered on its own merits including the details and nature of the offence.

16.2 If an applicant has received a caution for a traffic offence, given the nature of the offence and the profession of a taxi driver, the applicant may be given a warning as to his/her future conduct.

16.3 Cautions for more serious offences could lead to refusal of an application or the suspension or revocation of a licence.

## **17. Outstanding charges or summonses**

17.1 If the individual is the subject of an outstanding charge or summons their application can continue to be processed, but the application will need to be reviewed at the conclusion of proceedings.

17.2 If the outstanding charge or summons involves a serious offence, then in the interests of public safety the application may be put on hold until proceedings are concluded or the licence may be refused.

17.3 A suspension or revocation of the licence of a driver takes effect at the end of the period of 21 days beginning with the day on which notice is given to the driver. If it appears that the interests of public safety require the suspension or revocation of the licence to have immediate effect, and the notice given to the driver includes a statement

that is so and an explanation why, the suspension or revocation takes effect when the notice is given to the driver. [Road Safety Act 2006, s 52, 2A&2B]

## **18. Licensing offences**

18.1 Convictions for offences contrary to taxi legislation such as plying for hire, overcharging and refusing to carry disabled persons would normally prevent a licence being granted or renewed unless the applicant has been free of such convictions for a period of at least 3 years.

## **19. Licences issued by other licensing authorities**

19.1 Applicants who hold a licence with one licensing authority should not automatically assume that their application will be granted by another. Each case will always be decided on its own merits.

## **20. Summary**

20.1 To summarise, a motoring/criminal history in itself may not automatically result in refusal and a current conviction for a serious crime need not bar an applicant permanently from becoming licensed. As the preceding paragraphs indicate, in most cases, an applicant would be expected to remain free from conviction for 3 to 15 years, according to circumstances, before an application can be considered. However, there may be occasions when an application can be allowed before 3 years free from conviction have elapsed.

20.2 Any person who has committed an offence and has to wait before an application is positively considered is more likely to value their licence and act accordingly.

20.3 While it is possible that an applicant may have a number of convictions that, individually, meet the above guidelines, the overall offending history must be considered when assessing an applicant's suitability to be licensed. A series of offences over a period of time is more likely to give cause for concern than an isolated minor conviction. Obviously some discretion can be afforded if an offence disclosed is isolated and there are mitigating circumstances, but the overriding consideration is the protection of the public.

## **Immediate revocation and suspension of Hackney Carriage and Private Hire Drivers licenses**

The Borough Council has adopted a procedure to suspend or revoke a driver's licence with immediate effect where the interests of public safety require such course of action. The power under Section 52 of The Road Safety Act 2006 has been delegated to the Executive Director of Environment and Planning and the Chief Executive of the Borough Council. The below flowchart sets out the procedure adopted:

Delegation to Executive Director; Environment and Planning (ED) and Chief Executive (CE) in relation to S52 of the Road Safety Act 2006

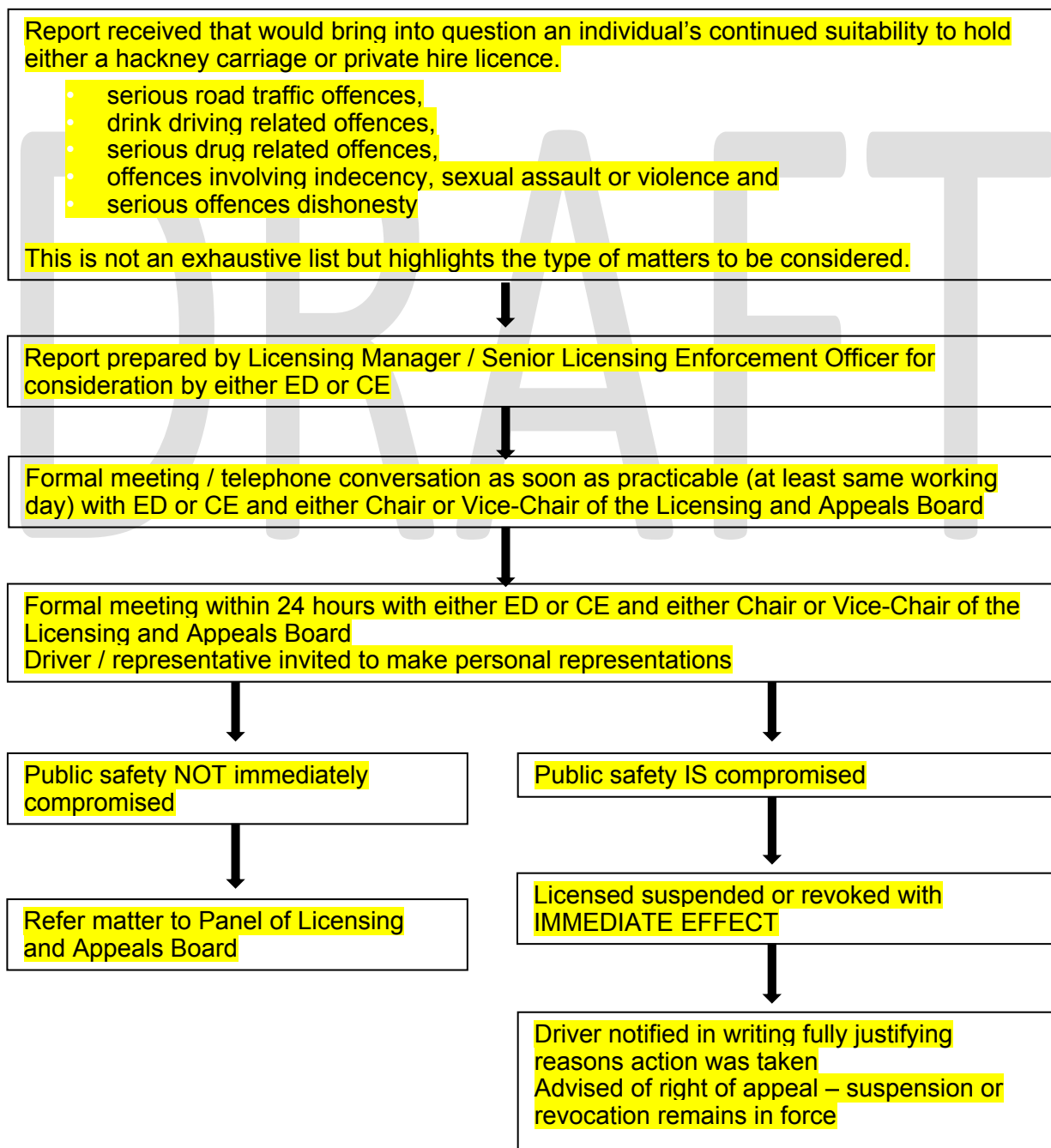

Borough Council of  
**King's Lynn &  
West Norfolk**



**Hackney Carriage  
&  
Private Hire Vehicle  
Compliance Testing Standards**

**Code of Practice**

**Standards of vehicle test to be applied in addition to  
the statutory requirements of the MOT testing**

**Introduction**

1. This document is intended to provide practical guidance to vehicle testers charged with assessing vehicles being issued with a certificate of compliance. It will also give a general insight into the type of examination the vehicle will be subjected to before it can be issued with a certificate of compliance.

2. It is the responsibility of owners, operators and drivers to ensure that their vehicles comply with the current rules and regulations of the appropriate Road Traffic Act and current Construction and Use Regulations at all times.

3. Where a vehicle is found not to conform to the requirements of the M.O.T. test and/or compliance test standards, that vehicle may have its licence suspended until the Borough Councils authorised officers are satisfied that the vehicle is fit to be licensed.

### **Guidance**

4. No adaptations, alterations, modifications, additional equipment, optional extras with the exception of tow bars fitted to a professional standard, are to be fitted to the vehicles without the prior approval of the Borough Council. Any owner wishing to alter or modify the vehicle, including the fitting of extras or alternative parts to those supplied by the manufacturer must seek prior permission from the Borough Council. Certain modifications may require special inspection by the Borough Council's authorised officer or his nominee before approval is given. (A fee may be applicable)

5. When a vehicle presented for compliance test fails on more than twelve items, that vehicle will have to be re-submitted for a full compliance test and a re-test fee will be charged. The vehicle proprietor will be issued with a failure sheet from the testing station, and the testing station will supply a copy of the failure sheet to The Licensing Team at the Borough Council.

6. Both M.O.T. and compliance tests must be completed by the same examiner at the same test station at the same time of day (obviously MOT testing is completed without avoidable distraction etc so compliance testing may be carried out before or after the MOT inspection). Compliance failure items must be resolved with the same garage at a later date.

7. The Borough Council of King's Lynn and West Norfolk recognises the need for approved MOT vehicle station examiners to test drive Hackney Carriage and Private Hire vehicles as part of the compliance inspection process.

8. Vehicles which are less than 3 years old and do not require an MOT are required to have a compliance test but are not required to have a standard MOT test.

## **Contents**

- 1. Exterior of the Vehicle**
- 2. Boot**
- 3. Engine Compartment**
- 4. Tyres & Spare Wheels**
- 5. Interior of Vehicle**
- 6. Fire Extinguishers & First Aid**
- 7. Vehicle Signage**
- 8. Underside of Vehicle**
- 9. Wheelchair Facilities**

DRAFT

<b>1.0 EXTERIOR OF THE VEHICLE</b>		
	<b>METHOD OF INSPECTION</b>	<b>PRINCIPAL REASON FOR FAILURE</b>
<b>1.1</b>	The exterior of the bodywork, the underside of vehicle is to be in a clean condition so as to facilitate full inspection of these areas.	Contamination preventing full or proper inspection.
<b>1.2</b>	Check operation of all external locks and catches, ensuring all doors can be securely closed locked and easily opened.	Defective external door catches or locks which prevent a door opening or closing properly.
<b>1.3</b>	Check all doors to ensure that they are aligned properly will open and close easily, and all gaps around doors are reasonably equal. Ensure boot lid opens/closes, and locks correctly and that all hinges and opening mechanisms adequately support the lid when it is in the open position	Poorly fitting doors to the vehicle. Worn locks, hinges or defective boot opening device.
<b>1.4</b>	Check to ensure all door hinges are in good condition, allowing free movement of door.	Door hinges defective
<b>1.5</b>	Check all wind check positions to ensure that doors are held in place when opened.	Wind checks fail to hold doors in place when opened
<b>1.6</b>	Examine the external body panels and structures for any evidence of corrosion, damage, or unsatisfactory repairs.	Corrosion or damage to the vehicle body or structure which adversely affects the appearance and/or safety of the vehicle. Replacement panels fitted that alter the effect of impact zones. Gaps reasonably unequal around panels.
<b>1.7</b>	Examine the external body and paint work for damage, which adversely affects the appearance of the vehicle.	Generally poor or damaged body or paintwork, dull, not in uniform in colour, and appearance, repairs visible, paint work of poor standard, overspray to any other part of the vehicle.
<b>1.8</b>	Check nearside and offside door/wing mirrors are fitted in a secure manner and that they function correctly. Ensure aerial is securely fixed.	Missing or defective exterior mirrors. Aerial not securely fixed.
<b>1.9</b>	Ensure front and rear bumpers are in good order (without any damage) and are securely fixed to the vehicle.	Damaged or inadequately secured front or rear bumpers, angled dents and end caps.
<b>1.10</b>	Ensure number plates are in good condition and are free of damage, and legible. White reflective at front and yellow reflective at rear.	Damage to front or rear number plates.
<b>1.11</b>	Examine rubber seals to doors and windows for damage, looseness or absence affecting performance of seals.	Damage or missing, or loose door seals which may cause draught, rainwater ingress unreasonable road noise or trip hazard.
<b>1.12</b>	Vehicles must be fitted with a key locking fuel cap or an internal means of lock or release.	Vehicle not having a method of securing fuel cap.
<b>1.13</b>	Reversing lights must be operable when fitted.	Reverse lights not operable.
<b>1.14</b>	All windows to be free of cracks and excessive marking.	Cracks in windscreen or rear window. Cracks in side windows or excessive marking on any window.
<b>1.15</b>	No glass, with the exception of a tinted sun-strip along the top of the windscreen, shall be tinted to such an extent as to obscure the view of the inside of the vehicle under normal workshop lighting conditions from a distance of 4 metres. Stretched Limousines are exempt from this requirement.	Glass is tinted to such an extent that the view is obscured inside the vehicle.

## 2.0 BOOT

METHOD OF INSPECTION		PRINCIPAL REASON FOR FAILURE
2.1	Examine the boot interior for evidence of damage, corrosion or water penetration.	Damage to the floor of the boot, inner wing panels or lid.
2.2	Examine the boot floor to ensure that it is in good condition and offers adequate protection to passenger's luggage stored in boot.	Excessive wear, damage or staining to the boot floor.
2.3	Examine interior of boot to ensure it is clean and free of dirt, dust, grease, litter etc.	Accumulation of dirt, grease, dust, litters or rubbish in the boot which could soil or damage luggage stored within.  Note: A five litre bottle of engine oil and water will be permitted.
2.4	Check boot for presence of any containers of any flammable or corrosive material (e.g. oil, petrol or diesel).	Containers for the storage of petrol, diesel, or any corrosive material shall not be carried in the vehicle.
2.5	Ensure that boot can be secured by a locking mechanism.	



<b>3.0 ENGINE COMPARTMENT</b>		
<b>METHOD OF INSPECTION</b>		<b>PRINCIPAL REASON FOR FAILURE</b>
<b>3.1</b>	Carry out visual inspection of engine compartment for signs of fuel, oil or water leaks.	Excessive oil, fuel or water leaks
<b>3.2</b>	Check to ensure that the battery is properly secured in its correct position.	Battery not adequately secured.
<b>3.3</b>	Examine all plastic/rubber or metal hoses for signs of deterioration or damage.	Worn or deteriorated hoses or pipes.
<b>3.4</b>	Check drive belt for correct adjustment and for signs of deterioration or damage.	Incorrectly adjusted or damaged drive belt
<b>3.5</b>	Check security of radiator and check hoses for leaks.	Leaking or insecure radiator.
<b>3.6</b>	Examine engine/transmission mounts for signs of deterioration or wear.	Insecure or deteriorated engine / transmission mountings.
<b>3.7</b>	Check clutch mechanisms for correct operation.	Leakage of fluid or mechanical wear in the clutch mechanisms.
<b>3.8</b>	Check operation of bonnet release/s catches.	Defective bonnet release catch or mechanisms.
<b>3.9</b>	Run engine to normal operational temperature to ensure the engine is not breathing out any excess fumes.	Engine breathing excess fumes.
<b>3.10</b>	Fuel cut off switch to be operable and present where known to be fitted as standard	Switch inoperable or removed.

<b>4.0 TYRES AND SPARE WHEEL</b>		
<b>METHOD OF INSPECTION</b>		<b>PRINCIPAL REASON FOR FAILURE</b>
<b>4.1</b>	Ensure that spare tyre is of same size and construction as those fitted to the road wheels or manufacturers supplied space saver wheel. Vehicles manufactured without a sparewheel/spacer saver are allowed a trye weld.	A spare wheel not provided with the vehicle. A tyre that is of a different size or construction or a non-manufactured supplied space saver wheel. No tyre weld provided
<b>4.2</b>	Examine tyres for signs of damage or excessive uneven wear ensure spare tyre complies with all legal requirements for tyres when fitted to the vehicle.	Damaged, worn, sub standard or otherwise illegal tyre.
<b>4.3</b>	Check to ensure all tyres are inflated to correct pressure for the vehicle.	Under inflated tyre.
<b>4.4</b>	Examine the wheel brace and jack provided to ensure they are in good working order.	Failure to provide a suitable jack/wheel brace.
<b>4.5</b>	Check to ensure the spare wheel fixing bracket (or similar device) will hold spare securely in position.	Spare wheel and tools not secured properly.
<b>4.6</b>	Check spare wheel rim for any signs of distortion or damage.	A seriously damaged or distorted rim which impairs the ability to hold the tyre.
<b>4.7</b>	All tyres to have a minimum tread depth of 1.6mm across 75% centre tread width with the remaining 25% to have tread pattern showing, including spare.	Tyres not showing the required tread depth.
<b>4.8</b>	If vehicle fitted with wheel trims as standard for that type of vehicle all must be present and in good repair.	Wheel trims missing, badly scuffed or damaged.
<p><b>Notes:</b></p> <ul style="list-style-type: none"> <li>• A mix of steel and cord radials will not be accepted.</li> <li>• Re-cut tyres are not acceptable.</li> <li>• Remould tyres will NOT be acceptable.</li> </ul>		

<b>5.0 INTERIOR OF VEHICLE</b>		
<b>METHOD OF INSPECTION</b>		<b>PRINCIPAL REASON FOR FAILURE</b>
<b>5.1</b>	Examine all floor and upholstery inside the vehicle for any damage, accumulation of dirt, dust, litter, general debris, cigarette ash, staining, or excessive wear. Examine roof lining for excessive staining and any damage.	A vehicle which is in a dirty condition with accumulations of dust, dirt, litter, debris, damage or staining (including roof lining).
<b>5.2</b>	Remove any mats from floor and examine carpeting for signs of leakage of water into the vehicle.	Evidence of leakage of water into vehicle.
<b>5.3</b>	Examine any mats to ensure they are not worn, damaged or a tripping hazard.	Upholstery including trims and panels which are damaged, excessively worn or holed/torn.
<b>5.4</b>	Sit in each of the seats within the vehicle to ensure that all seat cushions are in good condition and offer proper support.	Seat cushions or back rests which are in poor condition and/or offer poor support.
<b>5.5</b>	Examine all seats to ensure they are properly secured to the vehicle including fixed seat cushions.	Seats which are not adequately secured to the vehicle.
<b>5.6</b>	Check operation of interior lights, checking both manual and door operated switches. (Note: All doors to have switches fitted if fitted as standard by manufacturer).	Faulty interior light fitting/s or switch/es.
<b>5.7</b>	Examine rear view mirrors to ensure they are securely fixed.	A loose, cracked, damaged or missing rear mirror or one that impairs vision.
<b>5.8</b>	Check operation of the heater and demisters to ensure they work correctly.	Defective heater or demisters.
<b>5.9</b>	Check operation of clutch and also condition of pedal rubbers.	Defective clutch operation, worn or missing pedal rubbers.
<b>5.10</b>	Check operation of rear screen heater to ensure it is functioning correctly.	Defective rear screen heater.
<b>5.11</b>	Check operation of all window winders and door locks ensuring they open and close easily.	Window winders that do not allow windows to be lowered/raised easily. Defective window locks or associated fittings.
<b>5.12</b>	Check the operation of all door release catches including motion door locks to ensure that doors can be opened easily from within the vehicle.	Defective interior door release catches. Defective motion locks, motion locks fitted with override. Warning lamps inoperative, warning labels damaged or defaced.
<b>5.13</b>	Ensure childproof locks function correctly where fitted.	Defective childproof locks.
<b>5.14</b>	Check all door handles, and grab rails for condition and security. Ensure	Door handles, interior trims, mouldings, damaged, worn or not secured properly.

	childproof protection covers are in place and free of damage and held in place securely.	
<b>5.15</b>	Check for unpleasant odours within the vehicle.	Unacceptable smells.
<b>5.16</b>	If metal grill is fitted ensure it has no sharp edges or exposed parts that may lead to injury of passengers or driver, ensure grill is firmly secured. (Metal grill must not prevent operation of privacy partition).	Loose or incorrectly fitted grill or exposed parts that may cause injury. Privacy partition obstructed.
<b>5.17</b>	Check that a luggage grill/cover is fitted to estate cars and MPVs..	Luggage grill/cover not fitted.
<b>5.18</b>	Check that intercom systems (where fitted) are capable of being switched off within passenger compartment and that there are signs clearly visible explaining their use and how to switch them off. Check that a light is visible when intercom is on.	Intercom system not clearly marked. No means of passenger isolating system easily. Warning light not working.
<b>5.19</b>	Check condition of all electrical wiring to ensure it's routed correctly and poses no risk or hazard to passengers.	Wiring not routed correctly, insecure, damaged, poses a hazard or risk to passengers.
<b>5.20</b>	CCTV shall be firmly affixed where fitted.	Loose camera or screen fitted
<b>5.21</b>	Ensure gate around lever is present and not split.	Split or missing gaiter can allow debris to fall into gear linkage.
<p><u>Notes:</u></p> <ul style="list-style-type: none"> <li>• 5.1. Vehicles presented in a dirty untidy condition should not be tested.</li> <li>• 5.2. Where interior trims or roof lining have one rip or tear of not more than 75mm a good quality stitched repair is acceptable (patches not allowed).</li> <li>• 5.4. Patching is not acceptable on any interior upholstery</li> <li>• Advice may be given that a roof lining will be required to be renewed at the next test.</li> <li>• 5.16. If a glass partition is fitted this must to British Standards</li> <li>• 5.17. All trims, mouldings, door handles, grab handles to be free of damage.</li> <li>• 5.19 All electrical wiring to be in good order and securely routed. When going through panels the wiring must be protected by rubber grommets.</li> </ul>		

<b>6.0 FIRE EXTINGUISHERS &amp; FIRST AID</b>		
<b>METHOD OF INSPECTION</b>		<b>PRINCIPAL REASON FOR FAILURE</b>
<b><u>EXTINGUISHER</u></b>		
<b>6.1</b>	Check to ensure that the fire extinguisher is a 1-litre (3a) rated AFFF (aqueous film foam) type or powder.	Fire extinguisher not of approved type or rating.
<b>6.2</b>	Ensure that the vehicle registration number is clearly marked on the identification tag attached to the extinguisher.	Vehicle registration number is not clearly attached to identification tag on extinguisher.
<b>6.3</b>	Ensure that seal is in place and has not been tampered with and is intact.	Approved seal is not in place, or is damaged.
<b>6.4</b>	Visibly check extinguisher for signs of damage.	Visible signs of damage which would impair its use.
<b>6.5</b>	Extinguishers to be affixed within the driving compartment or in boot compartment in readily accessible position.	Extinguisher is not mounted securely, not readily accessible, and not mounted in approved position.
<b><u>FIRST AID</u></b>		
<b>6.6</b>	<p>A secure and clearly identifiable first aid container must be provided, to contain not less than:</p> <ul style="list-style-type: none"> <li>• 10 x medifresh antiseptic wipes or equivalent</li> <li>• 1 x 7.5cm bandage</li> <li>• 2 x triangular bandages</li> <li>• 24 x assorted plasters</li> <li>• 3 x large ambulance dressings</li> <li>• 2 x eye pads and elastic to secure</li> <li>• 12 x assorted safety pins</li> <li>• 1 x pair scissors</li> <li>• 2 x pairs disposable gloves</li> </ul>	The first aid container is not secure or clearly identifiable. The first aid box does not contain all the items listed opposite.
<p><b>Notes:</b></p> <ul style="list-style-type: none"> <li>• BAFE (British Approvals for Fire Equipment) is the only approved certification and maintenance scheme acceptable to the Authority.</li> <li>• Only persons approved by BAFE may maintain and certify extinguishers fitted to hackney carriage and private hire vehicles. All information concerning the standards for extinguishers is contained within BS EN2.</li> </ul>		

<b>7.0 VEHICLE SIGNAGE</b>	
<b>METHOD OF INSPECTION</b>	<b>PRINCIPAL REASON FOR FAILURE</b>
<b><u>HACKNEY CARRIAGE ONLY</u></b>	
<b>7.1</b>	Roof signs to be white in colour and securely fitted to the vehicle.
	Roof sign are not white in colour or securely fitted to vehicle.
<b>7.2</b>	Check that signage is displayed on the roof with the word "Taxi" on the front and that it can be read from a distance of 20 metres.
	The specified wording is not displayed on the roof sign or that it cannot be read from a distance of 20 metres.
<b>7.3</b>	Check that the sign shall be capable of being illuminated internally in such a manner that the word "TAXI" is illuminated at all times when the vehicle is plying for hire, but not otherwise.
	The roof sign is not capable of being illuminated internally.
<b><u>PRIVATE HIRE ONLY</u></b>	
<b>7.5</b>	The private hire vehicle shall <b>not</b> have a roof mounted sign of any kind.
	The private hire vehicle has a roof mounted sign.
<b>7.6</b>	The private hire vehicle shall not display any sign, which consists of or includes the word 'Taxi' or 'Cab' whether singular or plural, or 'Hire', or any word of a similar meaning or appearance to any of those words, whether alone or as part of another word. The only exception for use of the word 'Hire' displayed on a private hire vehicle is when the word is used in conjunction with the word 'Private' to form the word 'Private Hire'.
	The private hire vehicle has the wording 'taxi' or 'cab' or words of a similar meaning.
<b>7.7</b>	A sign must be displayed on each side of the vehicle specifying the operator name, with a telephone number for bookings, with the wording 'Pre-Booked Only' or 'Advance Bookings Only', with letters no smaller than 60mm in height. The sign must be clearly visible in a prominent position on the side of the vehicle, i.e black or dark coloured signage on a black vehicle would not be permitted.
	There is no signage prominently displayed on each side of the vehicle. The signage is not clearly visible. The writing for the signage is smaller than 60mm in height.

<b>8.0 UNDERSIDE OF VEHICLE</b>		
<b>METHOD OF INSPECTION</b>		<b>PRINCIPAL REASON FOR FAILURE</b>
<b>8.1</b>	Check to ensure the vehicle is free of any leakage of Water, Fuel and Oil.	The vehicle has an excessive fuel, oil or water leakage.
<b>8.2</b>	Check for security/wear in any drive shafts.	Insecure or worn drive shaft components or mounting.
<b>8.3</b>	Check for excess corrosion/damage/ that does not fall within the prescribed area as set out in the MOT testers manual.	Evidence of excess corrosion/damage to underside of vehicle.
<b>8.4</b>	Check for wear of any engine or transmission mounting that does not fall within the scope of the MOT testers manual.	Worn or damaged mountings
<b>8.5</b>	Ball joint rubbers to be free of damage.	Missing, torn or damaged mountings.
<b>8.6</b>	Damaged, torn or insecure inner drive shaft gaiters	Release of lubrication from joint.
<p><b>Notes:</b></p> <ul style="list-style-type: none"> <li>When a vehicle fails on fuel, oil, water leaks, on re-test it will be left running for no less than five minutes prior to inspection.</li> </ul>		

<b>9. WHEELCHAIR FACILITIES<sup>1</sup></b>		
	<b>METHOD OF INSPECTION</b>	<b>PRINCIPAL REASON FOR FAILURE</b>
9.1	Check condition of wheelchair restraints and equipment	Wheelchair restraints or equipment worn damaged or missing.
9.2	Check operation of wheelchair restraints.	Wheelchair restraints not functioning correctly.
9.3	Check operation and condition of disabled person's seatbelt.	Seatbelt worn, frayed, damaged or cut.
9.4	Check that appropriate approved ramps are securely installed in the boot of the vehicle.	Ramps not of an approved type, fitting or insecure.
9.5	Examine the ramps for any damage, sharp edges or corners.	Ramps in poor condition or damaged or sharp edges showing.
9.6	Check as applicable the non-slip provision and locating dowel pins are free of any damage.	Non slip provision worn or damaged, locating dowels damaged, worn or missing.
9.7	A wheelchair space shall not be less than: <ul style="list-style-type: none"> <li>• 1200mm measured in the longitudinal plane of the vehicle</li> <li>• 750mm measured in the transverse plane of the vehicle</li> <li>• 1300mm measured vertically from any part of the floor of the wheelchair space.</li> </ul>	Wheelchair space is less than: <ul style="list-style-type: none"> <li>• 1200mm measured in the longitudinal plane of the vehicle</li> <li>• 750mm measured in the transverse plane of the vehicle</li> <li>• 1300mm measured vertically from any part of the floor of the wheelchair space</li> </ul>
9.8	A wheelchair space shall allow the carriage of a wheelchair and a wheelchair user facing the front of the vehicle.	Wheelchair space does not allow carriage of wheelchair user facing frontwards.
9.9	Access to the vehicle must be possible from the road or pavement either by a lift or ramp. Any power-operated device must be capable of manual operation in the event of a power failure.	Access to vehicle is not possible from road or pavement by lift or ramp. Lifting device not capable of operating with no power.
9.10	A ramp should be of slip resistance material and at least 750mm in width. The ramp should be capable of being deployed both onto the road and onto a 125mm high kerb. The ramp when deployed should be securely located at the point of entry to the vehicle. For side & rear loading the ramps when deployed to the pavement should not exceed a slope of 1:4.	Ramp not slip resistant material. Width less than 750mm and not capable of being deployed onto 125mm high kerb. Ramp not securely located at entry point of vehicle. Slope exceeds 1:4.
9.11	The lift platform must be not less than 750mm in width and not less than 1200mm in length. The ramp should be equipped with a device to prevent the wheelchair rolling off and should operate at a vertical speed of less than 0.15m/s.	Lift platform less than 750mm in width or 1200mm in length. No device to prevent wheelchair rolling off ramp.
9.12	A 4 point anchorage system must be fitted, comprising two for attachment at the front of the wheelchair and two at the rear of the wheelchair, in accordance with ISO 10542-2.	No 4 point anchorage system installed in accordance with ISO 10542-2.

<sup>1</sup> Any additional Hackney Carriage Vehicle licenses issued must be wheelchair accessible (i.e. plate 53 onwards).



**CABINET REPORT**

<b>Open</b>		Would any decisions proposed :		
<b>Any especially affected Wards</b>	Discretionary /	Be entirely within Cabinet's powers to decide	YES	
	Operational	Need to be recommendations to Council	NO	
		Is it a Key Decision	NO	
Lead Member: Cllr Adrian Lawrence E-mail: <i>cllr.adrian.lawrence@west-norfolk.gov.uk</i>		Other Cabinet Members consulted:		
		Other Members consulted:		
Lead Officer: Duncan Hall E-mail: <i>Duncan.hall@west-norfolk.gov.uk</i> Direct Dial:01553 616445		Other Officers consulted: Ray Harding		
Financial Implications NO	Policy/Personnel Implications NO	Statutory Implications NO	Equal Impact Assessment YES If YES: Pre-screening/ Full Assessment	Risk Management Implications YES

Date of meeting: 1<sup>st</sup> December 2015

**STRATEGIC FORUM: FREEBRIDGE COMMUNITY HOUSING & BOROUGH COUNCIL OF KING'S LYNN & WEST NORFOLK**

**Summary**

This report proposes the establishment of a structured forum involving Freebridge Community Housing (FCH) and the Council. Whilst an effective relationship has been maintained since stock transfer in 2006, there is currently no existing forum for the two organisations to engage in discussion on strategic matters at a Senior Member/Director level.

In recent years FCH have developed into an increasingly important partner to the Borough Council not only in terms of the provision of social and affordable housing but also on wider community issues. Close working with FCH is vital in relation to speedily addressing the need of homeless people and families to whom the Council owes a statutory duty, as well as in terms of providing homes for people on the housing register. FCH are a key partner within the West Norfolk partnership and have played a significant part in a range of community initiatives, an example being their acquisition of the Providence Street Community facilities in King's Lynn which has been enhanced and improved both operationally and physically since FCH acquired the building from Norfolk County Council.

A strategic forum has been proposed (to include two meetings per year) that will provide an opportunity to ensure that respective priorities are understood; that new opportunities are explored; and that challenges and risks are identified. The proposal to establish formal arrangements for engagement comes at a time of significant change in the operating environment of registered housing providers.

**Recommendation**

- To agree the proposed terms of reference to a strategic forum between

the Council and FCH as set out in this report.

- To agree that the Leader and the Portfolio Holder with responsibility for Housing, along with the Chief Executive, represent the Council at the proposed Forum.

### **Reason for Decision**

A structured arrangement will help ensure that an effective relationship with FCH the major provider of affordable housing in the area is maintained.

## **Background**

The proposal for a structured arrangement to enable appropriate engagement regarding strategic matters has arisen for the following reasons:

The operating environment of registered providers of social housing is currently subject to change. National policy changes have necessitated the need for most housing providers to review their business plans based on reduced income assumptions. New cost pressures will lead to decision making and policy changes that will possibly have impacts on stake-holders including Councils. FCH will need to keep their policies, practices, and development strategies under review in this new operating environment.

The Borough Council has two places on FCH Board which are allocated by Annual Council. Alongside the tenant representation and the independent board members and two executive board members. These provide for direct engagement in the direction and management of the organisation.

The Council also holds a 'golden share' which is exercised by the Portfolio Holder with responsibility for housing. Certain key decisions are reserved to Shareholders meetings and require the agreement of the Borough Council. Perhaps the most significant of which relates to any proposed changes to the constitution of the organisation, for example if they were to be proposed changes to the board structure or perhaps for a merger with another association at some point in the future.

There is currently no framework for strategic priorities of the Council's Lead member or Leader to be directly voiced. The proposed forum will provide this opportunity and help maintain understanding and trust into the future.

Operational activities and issues will continue to be dealt with at an officer/ staff level within the respective organisations. The strategic forum will consider wider cross-cutting matters and explore opportunities to work together.

The proposed terms of reference are as follows:

## **Proposed Terms of Reference**

The aims of the joint group established by BCKLWN and Freebridge Community Housing shall be to work together in order to:-

- (a) Identify the potential for strategic joint action on a range of cross cutting issues which concern both Freebridge and the Council; in particular to ensure that partnership between both organisations is used effectively to the benefit of Freebridge tenants and/or the wider West Norfolk community.
- (b) Identify issues of common interest to the community, including housing need.
- (c) Review and monitor the outputs of joint involvement in Government funded schemes in liaison with appropriate agencies.
- (d) Discuss issues relating to the Borough Council's role as a Freebridge shareholder, for instance any proposed changes to the Freebridge constitution, and including Board Member recruitment.
- (e) Discuss any areas where the working relationship between Freebridge and the Borough Council could be improved or developed.
- (f) Share information around key areas of activity.

Membership shall be:-

- Freebridge: Chairman, Vice-Chairman, Chief Executive
- Borough Council: Leader, Portfolio Holder with responsibility for Housing, Chief Executive
- Co-optees as determined by the Group

The Group can be attended by Officers of the Council and Freebridge.

Venue: Alternatively Council offices and Freebridge premises

Convenor/Clerk: Host of the 'next' meeting

Meeting Frequency: Twice a year (but can meet more often if required)

## **Other Options Considered**

**Do nothing** – This option is not considered appropriate as it does not address the need for engagement at a strategic level. The new operating environment presents challenges and opportunities (including investment opportunities) that will need to be dealt with in an environment of understanding and co-

operation. The proposed formal strategic forum offers opportunities for both organisations to maintain and develop an effective relationship.

**Policy Implications**

There are no policy implications.

**Financial Implications**

There are no financial implications

**Personnel Implications**

There are no personnel implications

**Statutory Considerations**

The arrangements that the Council has with FCH connected with temporary accommodation and allocation of social housing tenancies assist the Council in delivering some of its statutory housing functions.

**Equality Impact Assessment (EIA)**

Pre-screening form attached as a Background Paper.

**Risk Management Implications**

Important issues could be misunderstood or opportunities missed without effective communication at the strategic level.

**Declarations of Interest / Dispensations Granted**

None

**Background Papers**

EIA pre screening form

**Please Note: If there are any positive or negative impacts identified in question 1, or there any 'yes' responses to questions 2 – 4 a full impact assessment will be required.**